

Instrument Manifolds

FOR THE PROCESS AND GAS INDUSTRIES

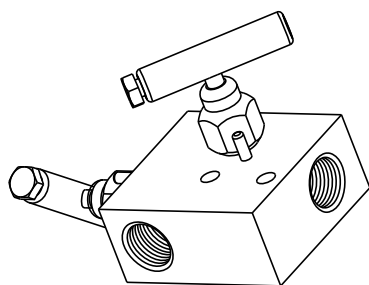

2, 3 and 5 Valve Manifold Designs

By-Pass Manifolds

Block & Bleed Manifolds

Purge Manifolds

Liquid Level Manifolds

Meter Manifolds

Miniature Manifolds

Pipe Mount Manifolds

Pressure & Pressure Instrument Manifolds

Short Mount Manifolds

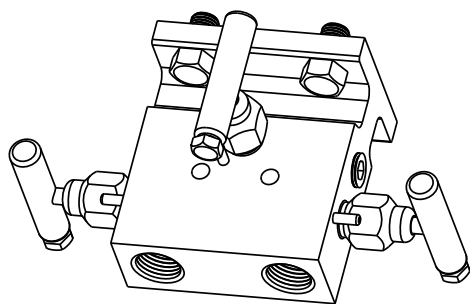

Patented Pressure-Core™ Stem Seal System with 5-year Warranty

Rock Hard Carbide Ball Seats

Soft “Roddable” Seat Styles

Carbon Steel and 316 SS Standard Materials

Standard 316 SS meets NACE (MR0175 Latest Revision)

Specialty Alloys Available

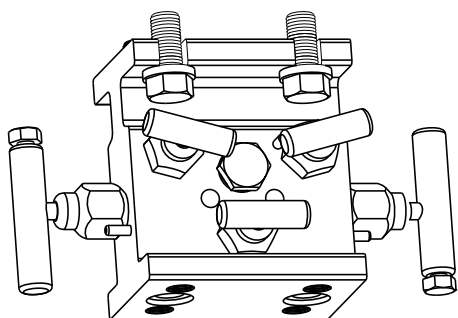

TABLE OF CONTENTS

PGI Model Number Index		Five-Valve Manifolds	
2	Cross Reference of model numbers and page numbers	43	.187" Orifice: NPT x NPT / NPT x Flg / Flg x Flg
		45	.250" Orifice: NPT x NPT / NPT x Flg / Flg x Flg
		47	.375" Orifice: NPT x NPT / NPT x Flg / Flg x Flg
Teflon® Pressure-Core™ Stem Seal Bonnet and Packing Design		Integral Coplanar™ Manifolds	
3	Teflon® Pressure-Core™ .125" .136" .187" .250" and .375" Orifice	49	Two, Three & Five Valve: NPT x Flange
Seat Designs		Purge Adapters	
4	Hard Ball Seat - .136" .187" and .375" Orifice	51	Flow & Level and Gauge Pressure
4	316 SS Cone Seat - .375" Orifice		
4	Soft Seat - .187" .250" and .375" Orifice	Direct-Mount™ Systems for UltraSonic Flow Meters	
4	Integral Metal to Metal Seat - .136" Orifice	53	Manifolds & Stabilized Connectors
4	Soft "Washer" Seat - .136" Orifice		
4	Soft "Washer" Seat - .125" .136" Orifice	Gauge Siphons & Swivels	
		55	NPT x NPT
Pressure and Temperature Charts		Bonnet and Packing Designs	
5	Pressure and Temperature Charts A thru F	56	Teflon® Mini Pressure-Core (Code T) - .136" Orifice
Manifold Seats & Seals		57	Teflon® Pressure-Core™ (Code T) - .187" .250" and .375" Orifice
6	Pressure and Temperature Quick Reference	58	Viton® O-Ring (Code V) - .125" .136" .187" .250" and .375" Orifice
By-Pass Manifolds		59	Adjustable Packed Bonnets (Codes T, G & P) - .136" .187" .375" Orifice
7	Flange x Flange / NPT x Flange	60	OS & Y Bonnet Codes (Codes G & P) - .187" and .375" Orifice
Liquid Level Manifolds		Options & Purge Port Locations	
9	NPT x Flange / Flange x Flange	61	Bonnet Lock Plates, Anti-Tamper Bonnets, Bonnet Handle Lock-outs and Integral Tube Fitting Connections
Meter Manifolds		61	Purge Port Locations & SS Tag
11	NPT x NPT / Flange x NPT	Accessories and Kits	
Pressure Instrument Manifolds		62	Versa-Mount Manifold Mounting Brackets, Coplanar™ Adapter Plate, Steam Trace Block, Versa-Mount Side Adapter and Flange Adapters
13	NPT x NPT, Single and Dual	63	Pipe Plugs, Manifold Flange Seals & Dielectric Kits
Two-Valve Block & Bleed Manifolds		Spare Parts	
15	NPT x NPT	64	.136", .187", .250" & .375" Orifice Spare Parts
17	NPT x NPT	Bolt Chart	
19	Stabilized NPT x NPT	65	Individual Hex Head Bolts, Bolt Washers and "MD" Coplanar™ Manifold Allen Head Bolts
Three-Valve Double Block & Bleed Manifolds		Warranty, Sales Policy, Special Orders and Oxygen & Chlorine Service	
21	NPT x NPT	66	Product Warranty, Teflon® Pressure-Core™ Stem Seal Warranty, Sales Policy, Special Orders and Oxygen & Chlorine Service Overview
Two-Valve Block & Bleed Manifolds			
23	Versa-Mount NPT x NPT		
25	NPT x NPT		
27	NPT x NPT / NPT x Flange / Flange x Flange		
29	NPT x Flange		
31	NPT x NPT / NPT x Flange		
Three-Valve Miniature Manifolds			
33	NPT x NPT		
Three-Valve Fugitive Emissions Manifold			
35	NPT x Flange		
Three-Valve Manifolds			
37	.187" Orifice: NPT x NPT / NPT x Flg / Flg x Flg		
39	.250" Orifice: NPT x NPT / NPT x Flg / Flg x Flg		
41	.375" Orifice: NPT x NPT / NPT x Flg / Flg x Flg		

Notes

Coplanar™ is a trademark of Rosemount®, Inc.
Rosemount® is a registered trademark of Rosemount®, Inc.

MODEL NUMBER INDEX

model no. index

model number	page no.	model number	page no.
A7-507 Gauge Siphon	55	M-905 Manifold for UltraSonic Flow Meters	53 - 54
A7-508 Gauge Siphon	55	M-906 Manifold for UltraSonic Flow Meters	53 - 54
A7-509 Gauge Siphon	55	M-923 Meter Manifold	11 - 12
A7-524 Gauge Siphon	55	M2-501 Three-Valve Manifold	39 - 40
A7-530 Gauge Swivel	55	M2-517 Two-Valve Block & Bleed Manifold	31 - 32
AK-003 Stabilized Connector for UltraSonic Meters	53 - 54	M2-573 Five-Valve Manifold	45 - 46
AK-062 Purge Adapter	51 - 52	M2-617 Two-Valve Block & Bleed Manifold	31 - 32
AK-064 Purge Adapter	51 - 52	M2-651 Three-Valve Manifold	39 - 40
AK-084 Purge Adapter	51 - 52	M2-673 Five-Valve Manifold	45 - 46
AK-088 Purge Adapter	51 - 52	M2-751 Three-Valve Manifold	39 - 40
AK-090 Purge Adapter	51 - 52	M2-773 Five-Valve Manifold	45 - 46
AK-079 Stabilized Connector for UltraSonic Meters	53 - 54	M3-500 Three-Valve Manifold	41 - 42
M-500 Three-Valve Manifold	37 - 38	M3-551 Three-Valve Manifold	41 - 42
M-501 Three-Valve Manifold	37 - 38	M3-573 Five-Valve Manifold	47 - 48
M-502 Five-Valve Manifold	43 - 44	M3-650 Three-Valve Manifold	41 - 42
M-504 By-Pass Manifold	7 - 8	M3-651 Three-Valve Manifold	41 - 42
M-505 Meter Manifold	11 - 12	M3-673 Five-Valve Manifold	47 - 48
M-506 Three-Valve Miniature Manifold	33 - 34	M3-750 Three-Valve Manifold	41 - 42
M-507 Two-Valve Block & Bleed Manifold	25 - 26	M3-751 Three-Valve Manifold	41 - 42
M-508 Two-Valve Block & Bleed Manifold	25 - 26	M3-773 Five-Valve Manifold	47 - 48
M-509 Meter Manifold	11 - 12	MD802 Integral Coplanar™ Manifold	49 - 50
M-514 By-Pass Manifold	7 - 8	MD804 Integral Coplanar™ Manifold	49 - 50
M-517 Two-Valve Block & Bleed Manifold	27 - 28	MD808 Integral Coplanar™ Manifold	49 - 50
M-518 Two-Valve Block & Bleed Manifold	27 - 28	MD810 Integral Coplanar™ Manifold	49 - 50
M-573 Five-Valve Manifold	43 - 44	MD812 Integral Coplanar™ Manifold	49 - 50
M-598 Pressure Instrument Manifold	13 - 14	MD813 Integral Coplanar™ Manifold	49 - 50
M-615 Two-Valve Block & Bleed Manifold	27 - 28	V-506 Hand Block Valve for Gauge Siphons	55
M-616 Two-Valve Block & Bleed Manifold	27 - 28	V-570 Two-Valve Block & Bleed Manifold	15 - 16
M-617 Two-Valve Block & Bleed Manifold	29 - 30	V-575 Two-Valve Block & Bleed Manifold	15 - 16
M-618 Two-Valve Block & Bleed Manifold	29 - 30	V-612 Two-Valve Block & Bleed Manifold	15 - 16
M-650 Three-Valve Manifold	37 - 38	V-613 Two-Valve Block & Bleed Manifold	15 - 16
M-651 Three-Valve Manifold	37 - 38	V-614 Two-Valve Block & Bleed Manifold	17 - 18
M-652 Five-Valve Manifold	43 - 44	V-615 Two-Valve Block & Bleed Manifold	17 - 18
M-657 Liquid Level Manifold	9 - 10	V-620 Two-Valve Versa-Mount Block & Bleed	23 - 24
M-658 Liquid Level Manifold	9 - 10	V-621 Two-Valve Versa-Mount Block & Bleed	23 - 24
M-673 Five-Valve Manifold	43 - 44	V-622 Two-Valve Versa-Mount Block & Bleed	23 - 24
M-694 Three-Valve Fugitive Emission Manifold	35 - 36	V-623 Two-Valve Versa-Mount Block & Bleed	23 - 24
M-698 Pressure Instrument Manifold	13 - 14	V-624 Two-Valve Versa-Mount Block & Bleed	23 - 24
M-715 Two-Valve Block & Bleed Manifolds	27 - 28	V-625 Two-Valve Versa-Mount Block & Bleed	23 - 24
M-716 Two-Valve Block & Bleed Manifolds	27 - 28	V-626 Two-Valve Block & Bleed Manifold	17 - 18
M-717 Two-Valve Block & Bleed Manifolds	29 - 30	V-627 Two-Valve Block & Bleed Manifold	17 - 18
M-718 Two-Valve Block & Bleed Manifolds	29 - 30	V-690 Three-Valve Double Block & Bleed	21 - 22
M-750 Three-Valve Manifold	37 - 38	V-692 Three-Valve Double Block & Bleed	21 - 22
M-751 Three-Valve Manifold	37 - 38	V-700 Two-Valve Stabilized Block & Bleed	19 - 20
M-752 Five-Valve Manifold	43 - 44	V-702 Two-Valve Stabilized Block & Bleed	19 - 20
M-757 Liquid Level Manifold	9 - 10	V-704 Two-Valve Stabilized Block & Bleed	19 - 20
M-758 Liquid Level Manifold	9 - 10	V-706 Two-Valve Stabilized Block & Bleed	19 - 20
M-773 Five-Valve Manifold	43 - 44	V-708 Two-Valve Stabilized Block & Bleed	19 - 20
		V-708 Manifold for UltraSonic Flow Meters	53 - 54

Teflon® Pressure-Core™ Stem Seal Bonnet and Packing Design

.125" .136" .187" .250" .375" ORIFICE

Pressure-Core™ Stem Seal

Compared to competitive valve designs, PGI's Pressure-Core™ Seal offers leak-free performance with no maintenance requirements. To support this claim, we tested the Pressure-Core™ Seal against the leading manufacturer's design. The tests simulated harsh plant operating environments and were performed by an independent laboratory in accordance with EPA Method 21.

How We Do It!

The Pressure-Core™ Seal consists of an outer Teflon® shell with an elliptical shaped Viton® O-ring core. The encapsulated core is "live-loaded" and provides constant outward pressure against the Teflon® shell, which flexes under pressure like an O-ring. The Teflon® shell offers the desired chemical resistance without periodic gland tightening as in conventional designs.

Our test results indicate that you can have a reliable, affordable and virtually leak-free valve requiring no costly, time-consuming maintenance. We stand behind our claim with a **five year warranty**, far exceeding the industry standard.

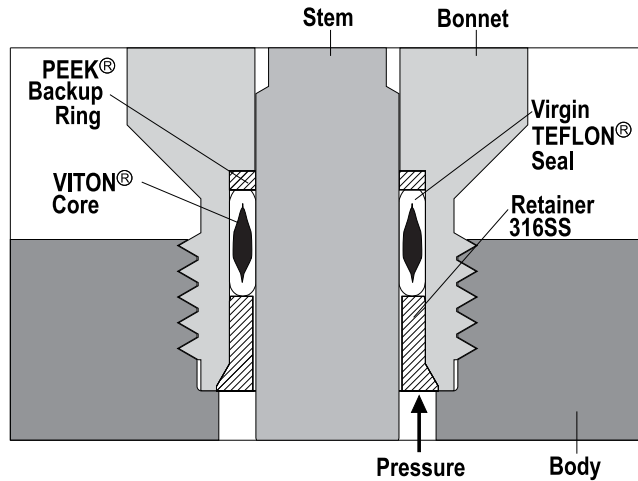

P A T E N T E D

5 year warranty

FUGITIVE EMISSIONS TEST RESULTS

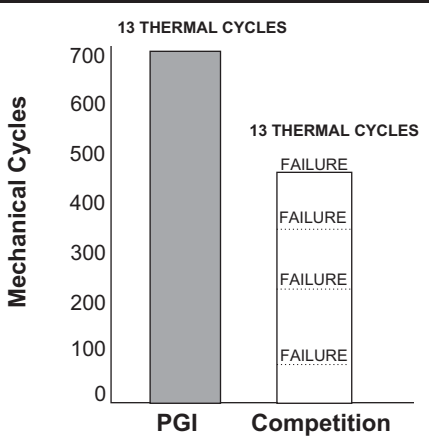

See for yourself how our Pressure-Core Seal not only outperforms the leading manufacturer's design, but sets a new industry standard.

TEST PROCEDURE

Valves mechanically cycled 50 times (full open to full close) at 1,000 PSI methane, then heated to 400° F and air cooled to ambient. Procedure repeated until failure.

FAILURE CRITERIA

100 PPM Leak
(Competitor's Emission Seal Warranty)

TEST RESULTS

PGI: The Pressure-Core Seal successfully completed **694** mechanical cycles and **15** thermal cycles. Maximum leakage throughout testing was **40 PPM**.

Competition: The leading manufacturer's "low emissions" graphite design failed on the **89th** mechanical cycle and on average every **125** cycles throughout the testing. Repeated maintenance was required between each failure to readjust the valve packing.

Seat Designs ~ Features and Benefits

.136" .187" .250" .375" ORIFICE

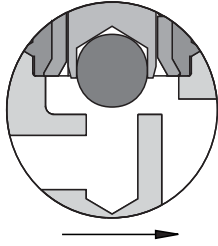

HARD BALL SEAT ~ .136" .187" .375" Orifice

FEATURES

- PGI Standard Carbide *Ball* Seat

BENEFITS

- Non-rotating ball eliminates seat galling and ball creasing
- Leak free, bubble tight seating
- Available in a variety of materials

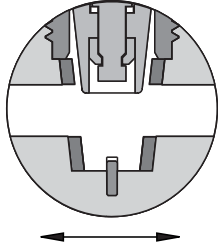

316 SS CONE SEAT ~ .375" Orifice

FEATURES

- PGI 316 SS *Cone* Seat

BENEFITS

- Non-rotating stem tip
- Roddable straight-through design
- Easily replaced
- Bi-directional flow

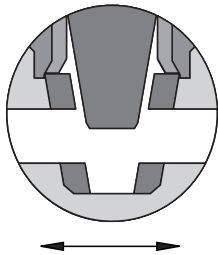

SOFT SEAT ~ .187" .250" .375" Orifice

FEATURES

- PGI Soft *Cone* Seat

BENEFITS

- Roddable straight-through design
- Leak free, bubble tight seating
- Easily replaced
- Available in a variety of materials
- Bi-directional flow

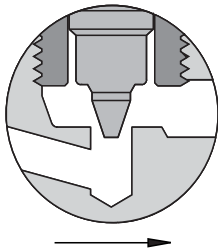

INTEGRAL METAL TO METAL SEAT ~ .136" Orifice [Mini Packed Valves]

FEATURES

- PGI Integral Metal Seat

BENEFITS

- Throttling and shut-off design
- Interchangeable between soft or metal seats

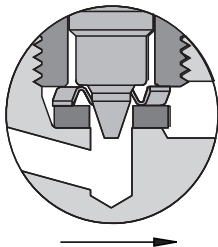

SOFT "WASHER" SEAT ~ .136" Orifice [Mini Packed Valves]

FEATURES

- PGI "Washer" Seat

BENEFITS

- Throttling and shut-off design
- Interchangeable between soft or metal seats
- Easily replaced
- Available in a variety of materials

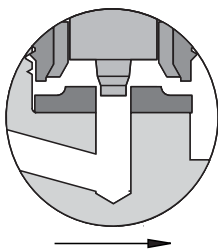

SOFT "WASHER" SEAT ~ .125" .136" Orifice

FEATURES

- PGI "Washer" Seat

BENEFITS

- Throttling and shut-off design
- Four times the sealing area
- Easily replaced
- Available in a variety of materials

Pressure and Temperature Charts

.136" .187" .250" .375" ORIFICE

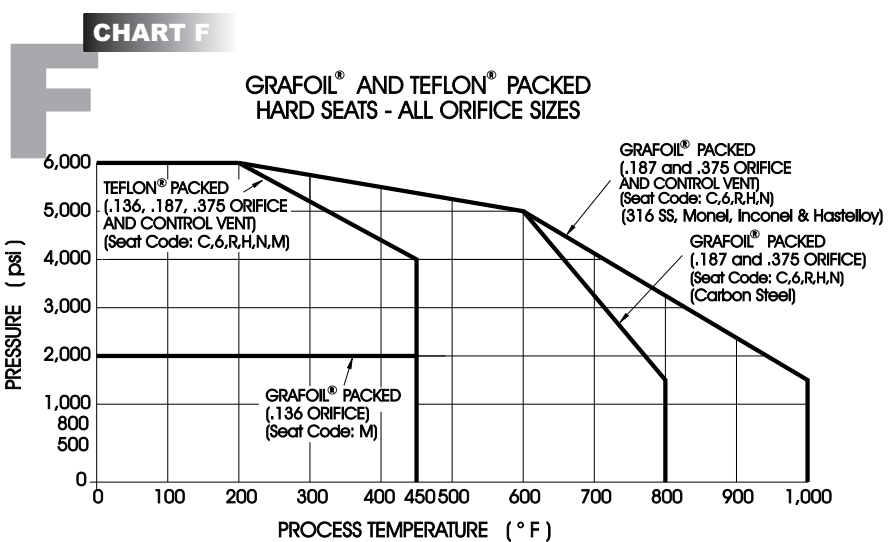
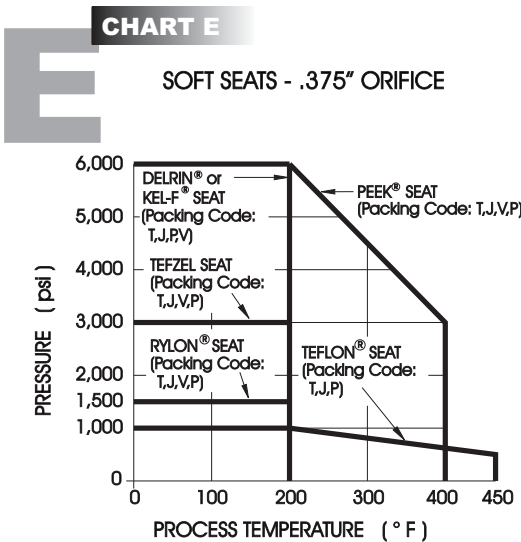
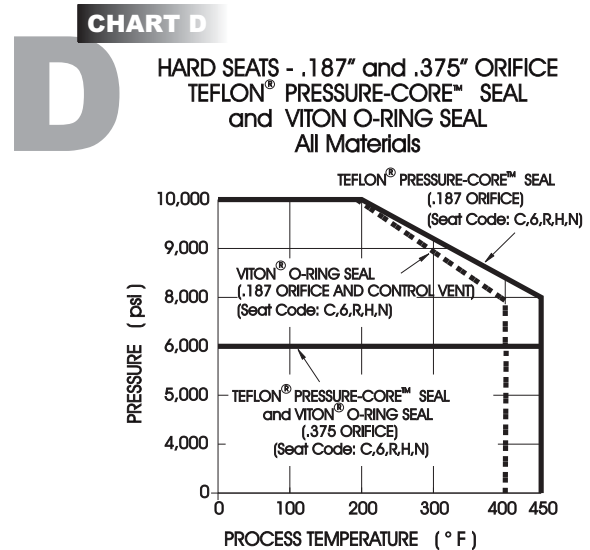
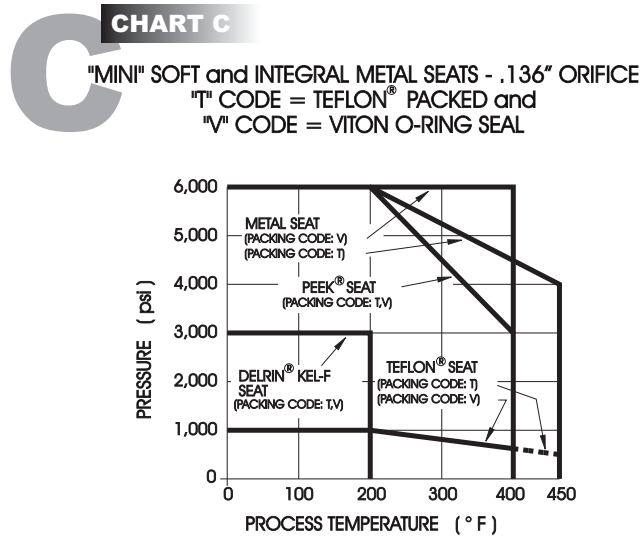
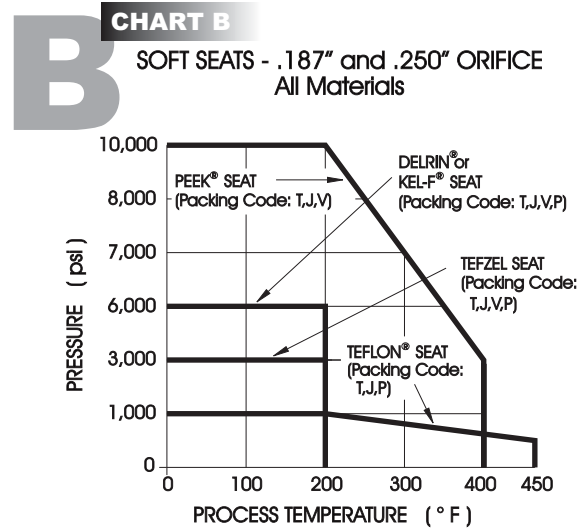
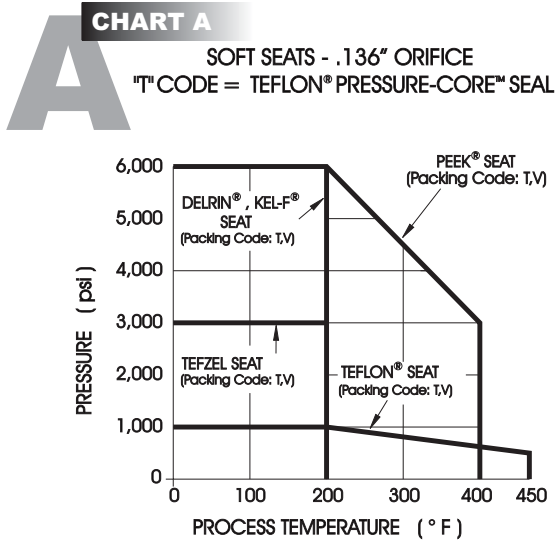

Manifold Seats & Seals

STANDARD BODY MATERIAL CODES				STANDARD STEM SEAL MATERIAL CODES						
CODE	MATERIAL	MAX TEMP	MIN TEMP	CODE	SEAL DESCRIPTION	MAX TEMP	MIN TEMP			
C	ASTM A108 - 1215 CS	500° F	- 20° F	G	Grafoil® Packed Style	800° F (CS) 1,000° F (SS)	- 20° F - 80° F			
S	ASTM A479 - 316 SS	1,000° F	- 100° F	J	Teflon® Pressure-Core Seal (Low Temperature)	450° F	- 50° F			
P	ASTM A105 CF	800° F	- 20° F	T	Teflon® Pressure-Core Seal (Standard)	450° F	- 40° F			
Non-standard body and bonnet materials such as Monel®, Inconel®, Hastelloy-C®, etc. are available on special factory order and carry the 316 SS temperature rating.				P	Teflon® Packed Style	450° F	- 80° F			
				K	Teflon® Pressure-Core Back-up	400° F	-40° F			
				V	Viton® O-Ring with filled Teflon Backup	400° F	- 15° F			
				Y	Graflon® Packed Style	600° F	- 40° F			
				T	"Mini" Teflon® Packed	450° F	- 15° F			
				STANDARD SOFT SEAT MATERIAL CODES				SOFT SEAT PRESSURE / TEMPERATURE RATINGS		
				CODE	MATERIAL	MAX TEMP	MIN TEMP	CODE	SEAL DESCRIPTION	MAX PRESSURE
				D	Delrin® Cone & Mini Washer	200° F	- 40° F	D	Delrin® Cone & Mini Washer	6,000 PSI @ 200° F
T	Teflon® Cone & Mini Washer	450° F	- 80° F	T	Teflon® Cone & Mini Washer	1,000 PSI @ 200° F				
L	Rylon® Cone (.375" Orifice) and Tefzel Mini Washers -.136" Orifice (Standard)	200° F	- 40° F	L	Rylon® (.375" Orifice Cone Only)	1,500 PSI @ 200° F				
Z	Tefzel Cone & Mini Washer	200° F	- 40° F	6	316 SS Cone (.375" Orifice Only)	6,000 PSI @ 200° F				
K	Kel-F® Cone & Mini Washer	200° F	- 100° F	Z	Tefzel Cone & Mini Washer	3,000 PSI @ 200° F				
P	PEEK® Cone & Mini Washer	400° F	- 40° F	K	Kel-F® Cone & Mini Washer	6,000 PSI @ 200° F				
				P	PEEK® Cone	10,000 PSI @ 200° F				
					PEEK® Mini Washer	6,000 PSI @ 200° F				
STANDARD HARD SEAT MATERIAL CODES				HARD SEAT PRESSURE / TEMPERATURE RATINGS						
CODE	MATERIAL	MAX TEMP	MIN TEMP	CODE	SEAL DESCRIPTION	MAX PRESSURE				
C	Carbide® Ball Nickel / Chrome Binder	800° F (CS) 1,000° F (SS)	- 100° F	C	Carbide® Ball	10,000 PSI @ 200° F				
6	316 SS Cone (.375" Orifice Block Valves Only) .187" & .375" Ball		- 100° F	6	316 SS Cone (.375" Orifice Only)	6,000 PSI @ 200° F				
R	Ceramic Ball		- 100° F	R	Ceramic Ball	10,000 PSI @ 200° F				
M	Integral Metal to Metal Seat		- 100° F	M	Integral Metal to Metal Seat	6,000 PSI @ 200° F				
N	Monel® Ball		- 100° F	N	Monel® Ball	10,000 PSI @ 200° F				
H	Hastelloy-C® Ball		-100° F	H	Hastelloy-C® Ball	10,000 PSI @ 200° F				

Notes

Monel® is a registered trademark of International Nickel Company.
 Hastelloy® is a registered trademark of Haynes International.
 Delrin®, Viton® and Teflon® are registered trademarks of the E.I. duPont de Nemours Company.
 Grafoil® is a registered trademark of Union Carbide Corporation.
 PEEK® is a registered trademark of ICI Americas, Inc.
 Kel-F® is a registered trademark of the 3M Company.
 Coplanar™ is a trademark of Rosemount®, Inc.
 Rosemount® is a registered trademark of Rosemount®, Inc.
 Parker® is a registered trademark of Parker Hannifin Corporation.
 Swagelok® is a registered trademark of The Swagelok® Companies.

By-Pass Manifolds

.187" ORIFICE

Description

Flange x Flange

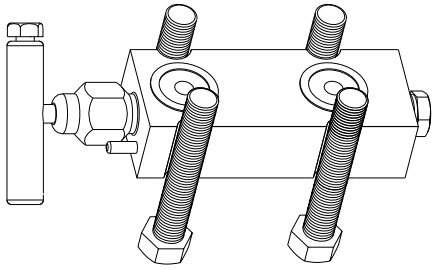

1/2" FNPT x Flange

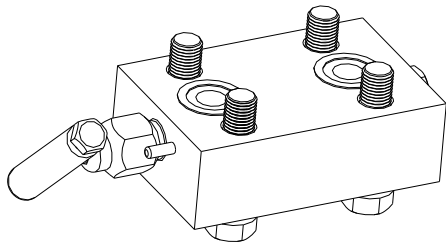

Body Style

M-504 Hard Seat

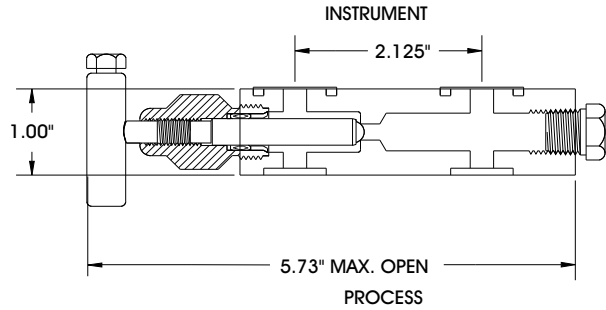

M-514 Hard Seat

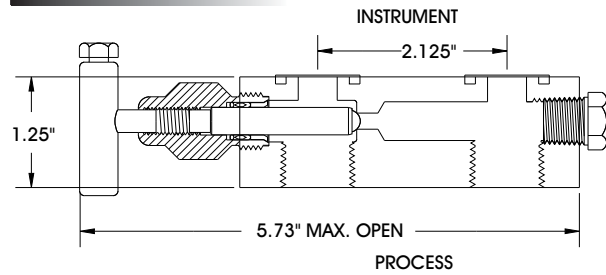

SEAT	MAX Cv RATINGS
Hard Ball	.53
Approx. Manifold Weight:	1.9 lbs each [M-504] 3.7 lbs each [M-514]

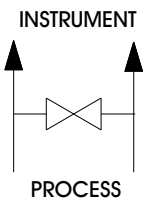

MATERIALS OF CONSTRUCTION

PART DESCRIPTION	CARBON STEEL	A105 CARBON STEEL	316 SS	MONEL®	HASTELLOY-C®
Body	ASTM A108-1215	ASTM A105-CF	ASTM A479-316	Consult Factory.	Consult Factory.
Bonnet	ASTM A108-1215	ASTM A479-316	ASTM A479-316		
Stem	ASTM A582-303	ASTM A479-316	ASTM A479-316		
Seal Retainer	ASTM A479-316	ASTM A479-316	ASTM A479-316		
Handle Assembly	ASTM A108	ASTM A108	ASTM A582 (18-8)		
Plug	ASTM A108	ASTM F593 (18.8)	ASTM A182-F (18-8)		
Mounting Bolts	ASTM A449-TYPE 1	ASTM A449-TYPE 1	ASTM A449-TYPE 1		

- Carbon Steel Manifolds are Zinc Cobalt Plated with Dichromate Dip
- 316 SS Manifolds Meet NACE MR0175 Requirements (Latest Revision)
- 100% Pressure Tested
- Carbon Steel Weld End Connection Bodies are AISI 1018

By-Pass Manifolds

.187" ORIFICE

BY-PASS MANIFOLDS

ORDERING INFORMATION

BODY STYLE	BODY CODE	SEAT CODE	STEM SEAL CODE	OPTION CODES
Hard Seat				
M - 5 0 4			-	
M - 5 1 4			-	

BODY CODE	
[Std.] Carbon Steel	C
A105 Carbon Steel	P
[Std.] 316 SS	S

HARD SEAT CODE	
C	Carbide Ball [Std.]
R	Ceramic Ball
6	316 SS Ball

STEM SEAL CODE	
[Std.] Teflon® Pressure-Core™	T
Grafoil® Packed	G
Viton® O-Ring	V
Low-Temp Pressure-Core™	J

OPTIONS

- **Bonnet Handle Lock-Out**
- Bonnet Lock Plates

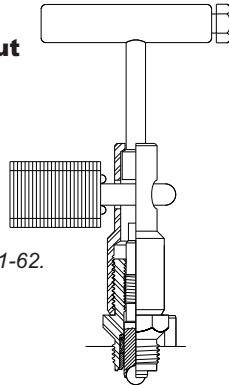

See Options/Accessories Pages 61-62.

OPTION CODE	OPTION DESCRIPTION
GA	Anti-Tamper Bonnet
GJ	Bonnet Lock-Out (Lock Not Provided)
MH	Viton® O-Ring Flange Seals
M7	Required Slotting for Rosemount® 1151 Transmitters Series 6 & Above (Flange Manifolds Only)
TH	Hydrostatic Testing
W	Safety Bonnet Lock Plate
WK	Paper Tag
W1	316 SS Tag (20 Characters ~ See page 61)
W3	300 SS Standard Length Flange Bolts (CS Standard)
W9	316 SS Standard Length Flange Bolts (CS Standard)
XL	Clean for Critical Service (Oxygen or Chlorine)

PRESSURE & TEMPERATURE

BODY MATERIAL	HARD SEAT	HARD SEAT
	Teflon Pressure-Core	Grafoil
Carbon Steel Code C	10,000 PSI @ 200° F 8,000 PSI @ 450° F	Not Available.
A105 Carbon Steel Code P	10,000 PSI @ 200° F 8,000 PSI @ 450° F	6,000 PSI @ 200° F 1,500 PSI @ 800° F
316 SS Code S	10,000 PSI @ 200° F 8,000 PSI @ 450° F	6,000 PSI @ 200° F 1,500 PSI @ 1,000° F
See Page 5:	Chart D	Chart F

Liquid Level Manifolds

.187" ORIFICE

Description

1/2" FNPT x Flange

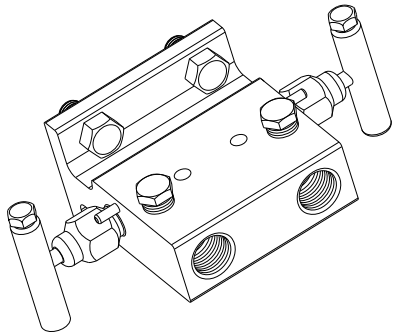

Body Style

M-658 Hard Seat

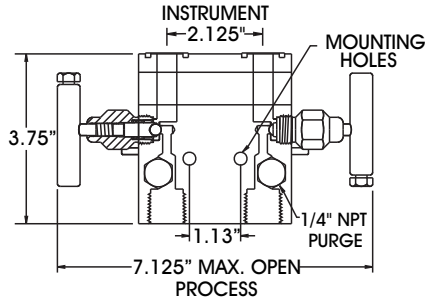

M-657 Soft Seat

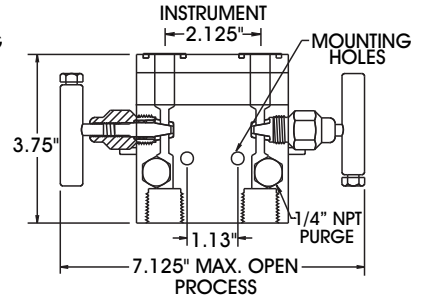

1/2" Flange x Flange

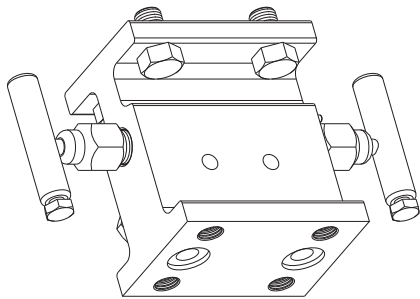

M-758 Hard Seat

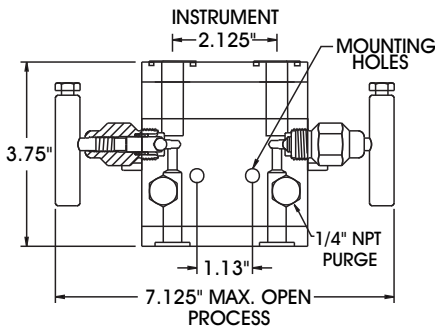

M-757 Soft Seat

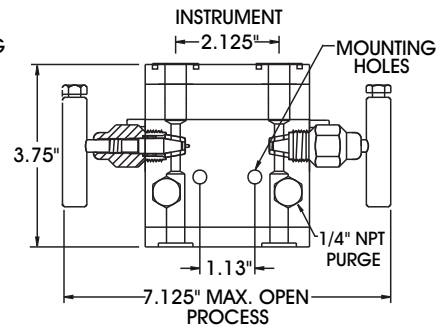

MATERIALS OF CONSTRUCTION

SEAT	MAX Cv RATINGS
Hard Ball	.53
Soft Cone	.83
Approx. Manifold Weight:	5.1 lbs each [M-657 / 658] 5.6 lbs each [M-757 / 758]

PART DESCRIPTION	CARBON STEEL	A105 CARBON STEEL	316 SS	MONEL®	HASTELLOY-C®
Body	ASTM A108-1215	ASTM A105-CF	ASTM A479-316	ASTM B164-N04400	ASTM A494 CW-12MW
Bonnet	ASTM A108-1215	ASTM A479-316	ASTM A479-316	ASTM B164-N04405	ASTM B574-N10276
Stem	ASTM A582-303	ASTM A479-316	ASTM A479-316	ASTM B164-N04405	ASTM B574-N10276
Seal Retainer	ASTM A479-316	ASTM A479-316	ASTM A479-316	ASTM B164-N04405	ASTM B574-N10276
Handle Assembly	ASTM A108	ASTM A108	ASTM A582 (18-8)	ASTM A582 (18-8)	ASTM A582 (18-8)
Plug(s)	ASTM A108	ASTM F593 (18.8)	ASTM A182-F (18-8)	ASTM B164-N04405	ASTM B574-N10276
Mounting Bolts	ASTM A449-TYPE 1	ASTM A449-TYPE 1	ASTM A449-TYPE 1	ASTM F593 (18-8)	ASTM F593 (18-8)

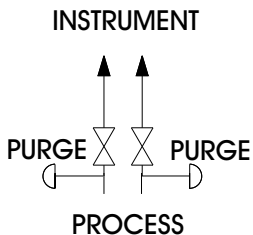

- Carbon Steel Manifolds are Zinc Cobalt Plated with Dichromate Dip
- 316 SS Manifolds Meet NACE MR0175 Requirements (Latest Revision)
- 100% Pressure Tested
- Carbon Steel Weld End Connection Bodies are AISI 1018

Liquid Level Manifolds

.187" ORIFICE

LIQUID LEVEL MANIFOLDS

ORDERING INFORMATION

BODY STYLE	BODY CODE	SEAT CODE	STEM SEAL CODE	OPTION CODES
Hard Seat				
M - 6 5 8				
M - 7 5 8			-	
Soft Seat				
M - 6 5 7				
M - 7 5 7			-	

BODY CODE	
[Std.] Carbon Steel	C
A105 Carbon Steel	P
[Std.] 316 SS	S
Monel®	M
Hastelloy-C®	H

HARD SEAT CODE	
[Std.] Carbide Ball	C
Ceramic Ball	R
316 SS Ball	6
Hastelloy-C®	H
K-Monel® Ball	N

SOFT SEAT CODE	
Delrin® Cone [Std.]	D
Kel-F® Cone	K
PEEK® Cone	P
Teflon® Cone	T
Tefzel Cone	Z

STEM SEAL CODE	
[Std.] Teflon® Pressure-Core™	T
Grafoil® Packed	G
Viton® O-Ring	V
Low-Temp Pressure-Core™	J
Teflon® Packed [Hard Seat Only]	P

OPTIONS

- **Versa-Mount Brackets**
- Bonnet Handle Lock-Out
- Bonnet Lock Plates
- Steam Trace Block
- Integral Tube Fitting Connections

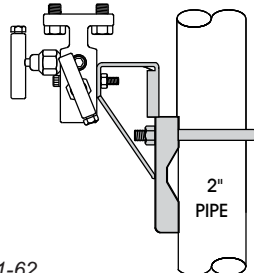

See Options/Accessories Pages 61-62.

OPTION CODE	OPTION DESCRIPTION
AP7	½" Female Pipe Socket Weld (Process Ports)
AU7	½" Integral Tube Fitting - Parker® A-LOK Dual Ferrules (Process Ports)
AV7	½" Integral Tube Fitting - Swagelok® Dual Ferrules (Process Ports)
GA	Anti-Tamper Bonnet
GK	Bonnet Lock-Out (Lock Not Provided)
MH	Viton® O-Ring Flange Seals
TC	Steam Trace Block - Carbon Steel
TH	Hydrostatic Testing
TS	Steam Trace Block - 316 SS
VC	CS Versa-Mount Bracket
VS	316 SS Versa-Mount Bracket
VCH	CS Heavy-Duty Versa-Mount Bracket
VSH	316 SS Heavy-Duty Versa-Mount Bracket
W	Safety Bonnet Lock Plate
WA	CS
WAW3	300 SS
WAW9	316 SS
WK	Paper Tag
W1	316 SS Tag (20 Characters ~ See page 61)
W3	300 SS Standard Length Flange Bolts (CS Standard)
W9	316 SS Standard Length Flange Bolts (CS Standard)
XL	Clean for Critical Service (Oxygen or Chlorine)

PRESSURE & TEMPERATURE

BODY MATERIAL	HARD SEAT	HARD SEAT
	Teflon Pressure-Core	Grafoil
Carbon Steel Code C	10,000 PSI @ 200° F 8,000 PSI @ 450° F	Not Available.
A105 Carbon Steel Code P	10,000 PSI @ 200° F 8,000 PSI @ 450° F	6,000 PSI @ 200° F 1,500 PSI @ 800° F
316 SS Code S	10,000 PSI @ 200° F 8,000 PSI @ 450° F	6,000 PSI @ 200° F 1,500 PSI @ 1,000° F
See Page 5:	Chart D	Chart F
BODY MATERIAL	SOFT SEAT (Delrin)	SOFT SEAT (Peek)
	Teflon Pressure-Core	Teflon Pressure-Core
Carbon Steel Code C	6,000 PSI @ 200° F Max.	10,000 PSI @ 200° F 3,000 PSI @ 400° F
316 SS Code S	6,000 PSI @ 200° F Max.	10,000 PSI @ 200° F 3,000 PSI @ 400° F
See Page 5:	Chart B	Chart B

Meter Manifolds

.187" ORIFICE

Description

1/4" FNPT x 1/4" FNPT

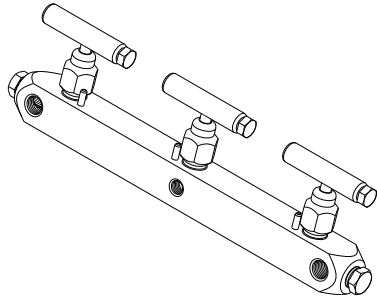

1/4" FNPT x 1/4" FNPT

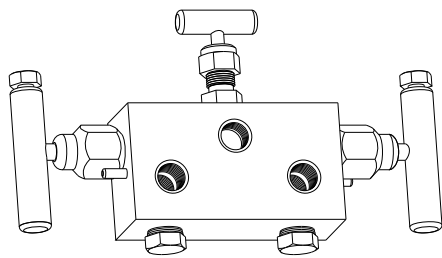

Flange x 1/4" FNPT

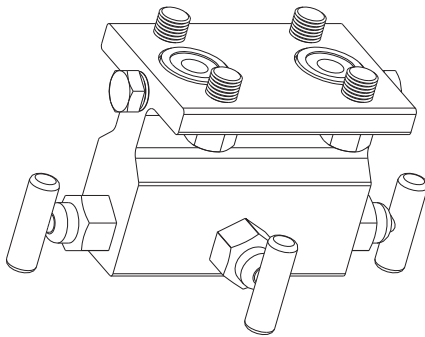

Body Style

M-505 Soft Seat

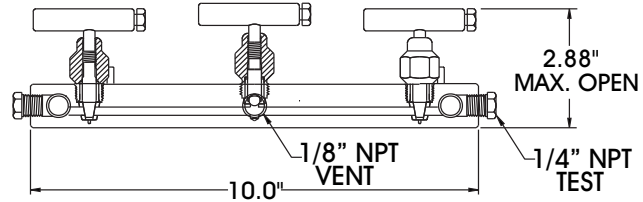

M-509 Soft Seat

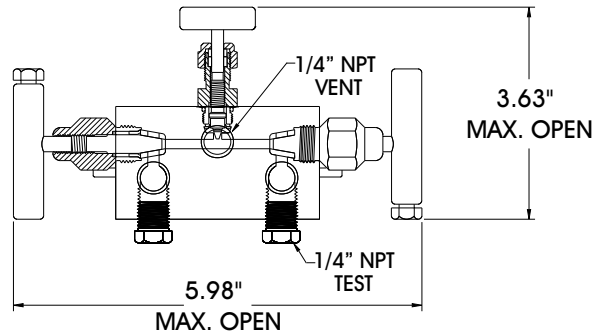

M-923 Soft Seat

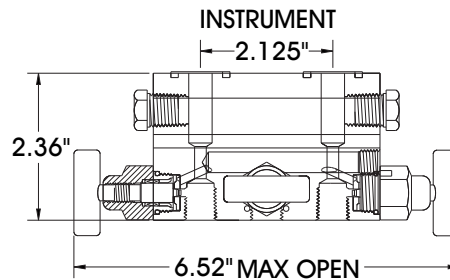

SEAT	MAX Cv RATINGS
Soft Cone	.83
Approx. Manifold Weight:	3.7 lbs each [M-505] 5.0 lbs each [M-509]

PART DESCRIPTION	CARBON STEEL	316 SS	MONEL®	HASTELLOY-C®
Body	ASTM A108-1215	ASTM A479-316	Consult Factory.	Consult Factory.
Bonnet	ASTM A108-1215	ASTM A479-316		
Stem	ASTM A582-303	ASTM A479-316		
Seal Retainer	ASTM A479-316	ASTM A479-316		
Handle Assembly	ASTM A108	ASTM A582 (18-8)		
Plug(s)	ASTM A108	ASTM A182-F (18-8)		

- Carbon Steel Manifolds are Zinc Cobalt Plated with Dichromate Dip
- 316 SS Manifolds Meet NACE MR0175 Requirements (Latest Revision)
- 100% Pressure Tested

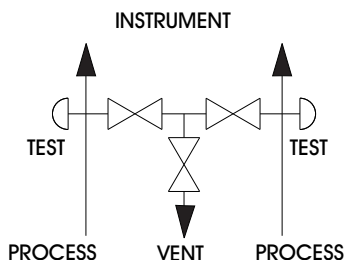

Meter Manifolds

.187" ORIFICE

METER MANIFOLDS

ORDERING INFORMATION

BODY STYLE	BODY CODE	SEAT CODE	STEM SEAL CODE	OPTION CODES
Soft Seat				
M - 505			-	
M - 509			-	
M - 923				

BODY CODE	
[Std.] Carbon Steel	C
[Std.] 316 SS	S

SOFT SEAT CODE	
D	Delrin® Cone/Washer [Std.]
K	Kel-F® Cone/Washer
P	PEEK® Cone/Washer
T	Teflon® Cone/Washer
Z	Tefzel Cone/Washer

STEM SEAL CODE	
[Std.] Teflon® Pressure-Core™	T
Viton® O-Ring	V
Low-Temp Pressure-Core™	J
Fluorosilicone Pressure-Core™	L

OPTIONS

- **Bonnet Lock Plates**
- Bonnet Handle Lock-Out

See Options/Accessories Pages 61-62.

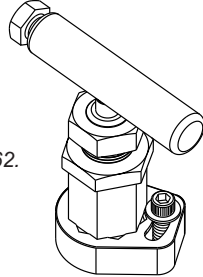

OPTION CODE	OPTION DESCRIPTION
C4	(2) .187" Orifice Block Valves - 1/4" NPT F x M V-501CDT/SDT
GA	Anti-Tamper Bonnet (All Positions - M-505 Only)
*GC	Anti-Tamper Bonnet (Isolate Valve(s) Only - M-505 Only)
GD	Anti-Tamper Bonnet (Equalizer Valve(s) Only - M-505 & M-509 Only)
GE	Anti-Tamper Bonnet (Vent Valve Only - M-505 Only)
GJ	Bonnet Lock-Out (All Positions - Lock Not Provided - M-505 Only)
*GK	Bonnet Lock-Out (Isolate Valve Only - Lock Not Provided - M-505 Only)
GL	Bonnet Lock-Out (Equalizer Valve(s) Only - Lock Not Provided - M-505 & M-509 Only)
GM	Bonnet Lock-Out (Vent Valve Only - Lock Not Provided - M-505 Only)
MH	Viton® O-Ring Flange Seals (M-923 Only)
W	Safety Bonnet Lock Plate
WK	Paper Tag
W1	316 SS Tag (20 Characters ~ See page 61)
XL	Clean for Critical Service (Oxygen or Chlorine)
	* Only with C4 Option on M-505.

PRESSURE & TEMPERATURE

BODY MATERIAL	SOFT SEAT (Delrin)	SOFT SEAT (Delrin)
	M-505	M-509
Carbon Steel	6,000 PSI @ 200° F Max.	3,000 PSI @ 200° F Max.
316 SS	6,000 PSI @ 200° F Max.	3,000 PSI @ 200° F Max.
See Page 5:	Chart B	Chart C

Pressure Instrument Manifolds

.187" ORIFICE

Description

1/2" FNPT x 1/2" FNPT

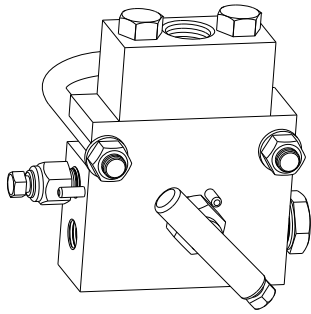

Single Instrument

M-598 Hard Seat

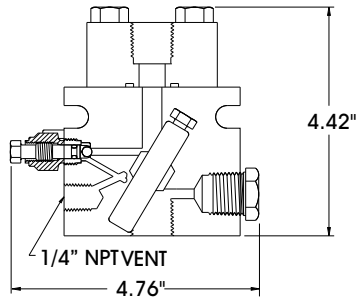

1/2" FNPT x (2) 1/2" FNPT

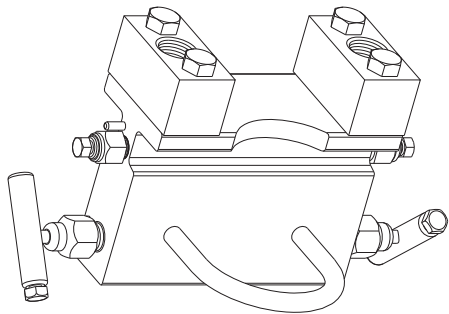

Dual Instrument

M-698 Hard Seat

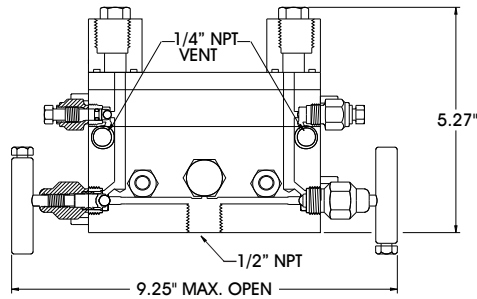

MATERIALS OF CONSTRUCTION

SEAT	MAX Cv RATINGS
Hard Ball / Cone	.53
Approx. Manifold Weight:	5.0 lbs each [M-598] 10.0 lbs each [M-698]

PART DESCRIPTION	CARBON STEEL	A105 CARBON STEEL	316 SS	MONEL®	HASTELLOY-C®
Body	ASTM A108-1215	ASTM A105-CF	ASTM A479-316	ASTM B164-N04405 or ASTM B164-N04400	ASTM B575-N10276 or ASTM A494 CW-12MW
Bonnet	ASTM A108-1215	ASTM A479-316	ASTM A479-316	ASTM B164-N04405	ASTM B574-N10276
Stem	ASTM A582-303	ASTM A479-316	ASTM A479-316	ASTM B164-N04405	ASTM B574-N10276
Seal Retainer	ASTM A479-316	ASTM A479-316	ASTM A479-316	ASTM B164-N04405	ASTM B574-N10276
Handle Assembly	ASTM A108	ASTM A108	ASTM A582 (18-8)	ASTM A582 (18-8)	ASTM A582 (18-8)
Plug(s)	ASTM A108	ASTM F593 (18-8)	ASTM A182-F (18-8)	ASTM B164-N04405	ASTM B574-N10276
Mounting Bolts	ASTM A449-TYPE 1	ASTM A449-TYPE 1	ASTM A449-TYPE 1	ASTM F593 (18-8)	ASTM F593 (18-8)
U-Bolts	ASTM A449-G15	ASTM A449-G15	300 SERIES SS	300 SERIES SS	300 SERIES SS

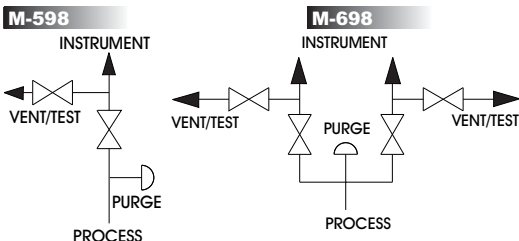

- Carbon Steel Manifolds are Zinc Cobalt Plated with Dichromate Dip
- 316 SS Manifolds Meet NACE MR0175 Requirements (Latest Revision)
- 100% Pressure Tested
- Carbon Steel Weld End Connection Bodies are AISI 1018

Pressure Instrument Manifolds

.187" ORIFICE

PRESSURE INSTRUMENT MANIFOLDS

ORDERING INFORMATION

BODY STYLE	BODY CODE	SEAT CODE	STEM SEAL CODE	OPTION CODES
Hard Seat				
M - 5 9 8			-	
M - 6 9 8			-	

BODY CODE	
[Std.] Carbon Steel	C
A105 Carbon Steel	P
[Std.] 316 SS	S
Monel®	M
Hastelloy-C®	H

HARD SEAT CODE	
C	Carbide Ball [Std.]
R	Ceramic Ball
6	316 SS Ball
H	Hastelloy-C® Ball
N	K-Monel® Ball

STEM SEAL CODE		
Block Valve(s)	Vent Valve(s)	
[Std.] Teflon® Pressure-Core™	Viton® O-Ring [Std.]	T
Grafoil® Packed	Grafoil® Packed	G
Viton® O-Ring	Viton® O-Ring	V
Teflon® Packed	Teflon® Packed	P
Low-Temp Pressure-Core™	Fluorosilicone O-Ring	J

OPTIONS

- **Integral Tube Fitting Connections**
- Bonnet Handle Lock-Out
- Bonnet Lock Plates

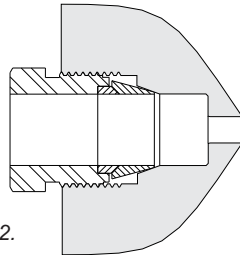

See Options/Accessories Pages 61-62.

OPTION CODE	OPTION DESCRIPTION
CVSCF	Vent Valve Seal Material: Fluorosilicone O-Ring
CVSCG	Vent Valve Seal Material: Grafoil® Packed
CVSCP	Vent Valve Seal Material: Teflon® Packed
GC	Anti-Tamper Bonnet (Isolate Valve(s) Only)
GK	Bonnet Lock-Out (Isolate Valve(s) Only - Lock Not Provided)
TH	Hydrostatic Testing
W	Safety Bonnet Lock Plate
WK	Paper Tag
W1	316 SS Tag (20 Characters ~ See page 61)
W3	300 SS Standard Length Flange Bolts (CS Standard)
W9	316 SS Standard Length Flange Bolts (CS Standard)
XL	Clean for Critical Service (Oxygen or Chlorine)

PRESSURE & TEMPERATURE

BODY MATERIAL	HARD SEAT	HARD SEAT
	Teflon Pressure-Core	Grafoil
<i>Carbon Steel</i> Code C	10,000 PSI @ 200° F 8,000 PSI @ 450° F	Not Available.
<i>A105 Carbon Steel</i> Code P	10,000 PSI @ 200° F 8,000 PSI @ 450° F	6,000 PSI @ 200° F 1,500 PSI @ 800° F
<i>316 SS</i> Code S	10,000 PSI @ 200° F 8,000 PSI @ 450° F	6,000 PSI @ 200° F 1,500 PSI @ 1,000° F
See Page 5:	Chart D	Chart F

Two-Valve Block & Bleed Manifolds

.187" ORIFICE

Description

1/2" MNPT x 1/2" FNPT

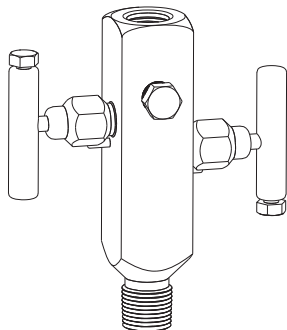

1/2" MNPT x 1/2" MNPT

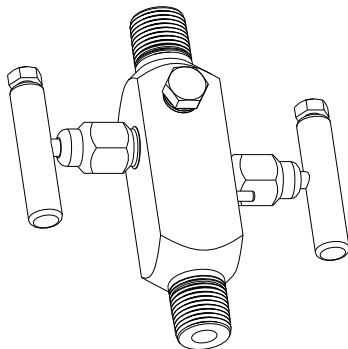

Body Style

V-570 Hard Seat

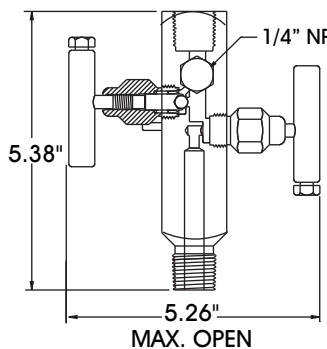

V-575 Soft Seat

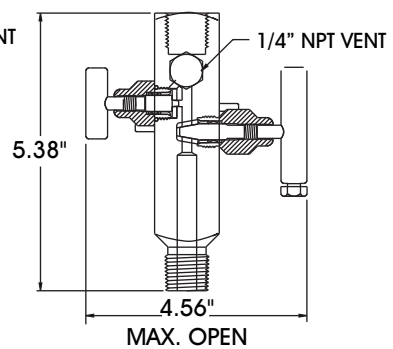

V-612 Hard Seat

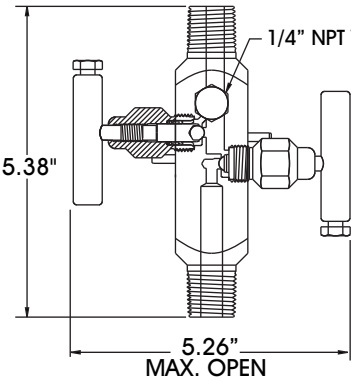

V-613 Soft Seat

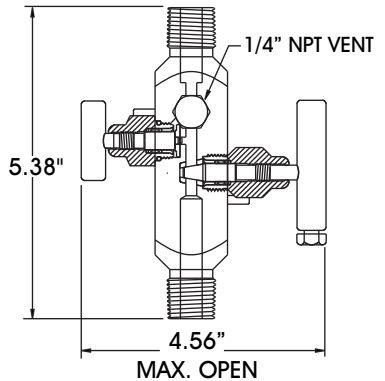

Above drawings shown with P9 Pipe Plug Option.

MATERIALS OF CONSTRUCTION

SEAT	MAX Cv RATINGS
Hard Ball	.53
Soft Cone	.83

Approx. Manifold Weight: 3.0 lbs each [V-570 / 575 / 612 / 613]

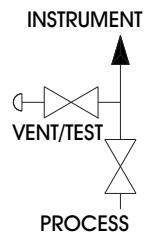

PART DESCRIPTION	CARBON STEEL	A105 CARBON STEEL	316 SS	MONEL®	HASTELLOY-C®
Body	ASTM A108-1215	ASTM A105-CF	ASTM A479-316	ASTM B164-N04405	ASTM B574-N10276
Bonnet	ASTM A108-1215	ASTM A479-316	ASTM A479-316	ASTM B164-N04405	ASTM B574-N10276
Stem	ASTM A582-303	ASTM A479-316	ASTM A479-316	ASTM B164-N04405	ASTM B574-N10276
Seal Retainer	ASTM A479-316	ASTM A479-316	ASTM A479-316	ASTM B164-N04405	ASTM B574-N10276
Handle Assembly	ASTM A108	ASTM A108	ASTM A582 (18-8)	ASTM A582 (18-8)	ASTM A582 (18-8)
Plug(s)	ASTM A108-1215	ASTM F593 (18.8)	ASTM A182-F (18-8)	ASTM B164-N04405	ASTM B574-N10276

- Carbon Steel Manifolds are Zinc Cobalt Plated with Dichromate Dip
- 316 SS Manifolds Meet NACE MR0175 Requirements (Latest Revision)
- 100% Pressure Tested
- Carbon Steel Weld End Connection Bodies are AISI 1018

Two-Valve Block & Bleed Manifolds

.187" ORIFICE

TWO-VALVE BLOCK & BLEED MANIFOLDS

ORDERING INFORMATION

BODY STYLE	BODY CODE	SEAT CODE	STEM SEAL CODE	OPTION CODES
Hard Seat				
V - 570			-	
V - 612			-	
Soft Seat				
V - 575			-	
V - 613			-	

BODY CODE	
[Std.] Carbon Steel	C
A105 Carbon Steel	P
[Std.] 316 SS	S
Monel®	M
Hastelloy-C®	H

HARD SEAT CODE		SOFT SEAT CODE	
[Std.] Carbide Ball	C	D	Delrin® Cone / Washer [Std.]
Ceramic Ball	R	K	Kel-F® Cone / Washer
316 SS Ball	6	P	PEEK® Cone / Washer
Hastelloy-C® Ball	H	T	Teflon® Cone / Washer
K-Monel® Ball	N	Z	Tefzel Cone / Washer

STEM SEAL CODE	
[Std.] Teflon® Pressure-Core™	T
Grafoil® Packed	G
Teflon® Packed [Hard Seat Only]	P
Viton® O-Ring	V
Low-Temp Pressure-Core™	J

OPTIONS

- **Bonnet Handle Lock-Out**
- Bonnet Lock Plates

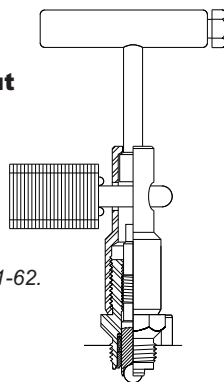

See Options/Accessories Pages 61-62.

OPTION CODE	OPTION DESCRIPTION
AM7	½" Male Pipe Socket Weld (Process Port)
GA	Anti-Tamper Bonnet (All Positions - Hard Seats Only)
GC	Anti-Tamper Bonnet (Isolate Valve Only)
GE	Anti-Tamper Bonnet (Vent Valve Only - Hard Seats Only)
GJ	Bonnet Lock-Out (All Positions - Lock Not Provided - Hard Seats Only)
GK	Bonnet Lock-Out (Isolate Valve Only - Lock Not Provided)
GM	Bonnet Lock-Out (Vent Valve Only - Lock Not Provided - Hard Seats Only)
P9	¼" Hex Head Pipe Plug in Vent/Test Port
TH	Hydrostatic Testing
W	Safety Bonnet Lock Plate
WK	Paper Tag
W1	316 SS Tag (20 Characters ~ See page 61)
XL	Clean for Critical Service (Oxygen or Chlorine)

PRESSURE & TEMPERATURE

BODY MATERIAL	HARD SEAT	HARD SEAT
	Teflon Pressure-Core	Grafoil
Carbon Steel Code C	10,000 PSI @ 200° F 8,000 PSI @ 450° F	Not Available.
A105 Carbon Steel Code P	10,000 PSI @ 200° F 8,000 PSI @ 450° F	6,000 PSI @ 200° F 1,500 PSI @ 800° F
316 SS Code S	10,000 PSI @ 200° F 8,000 PSI @ 450° F	6,000 PSI @ 200° F 1,500 PSI @ 1,000° F
See Page 5:	Chart D	Chart F
BODY MATERIAL	SOFT SEAT (Delrin)	SOFT SEAT (Peek)
	Teflon Pressure-Core	Teflon Pressure-Core
Carbon Steel Code C	6,000 PSI @ 200° F Max.	10,000 PSI @ 200° F 3,000 PSI @ 400° F
316 SS Code S	6,000 PSI @ 200° F Max.	10,000 PSI @ 200° F 3,000 PSI @ 400° F
See Page 5:	Chart B	Chart B

Two-Valve Block & Bleed Manifolds

.187" ORIFICE

Description

1/2" FNPT x 1/2" MNPT

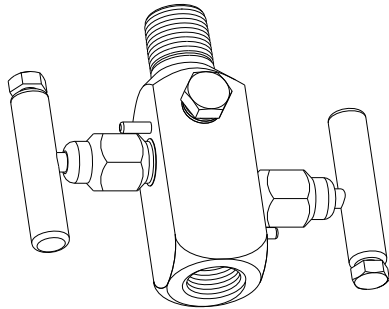

1/2" FNPT x 1/2" FNPT

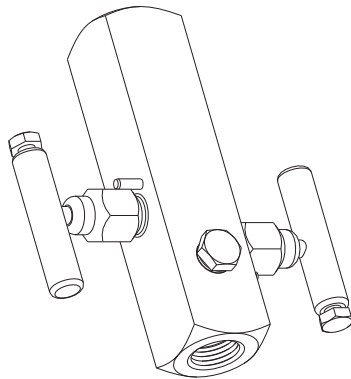

Body Style

V-614 Hard Seat

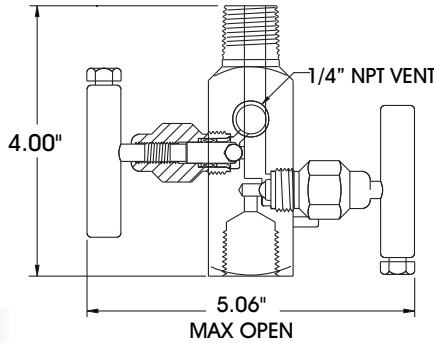

V-615 Soft Seat

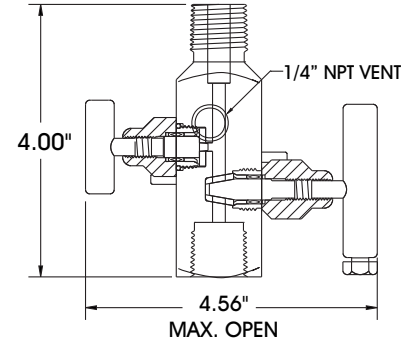

V-626 Hard Seat

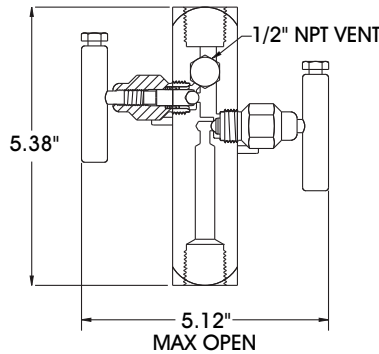

V-627 Soft Seat

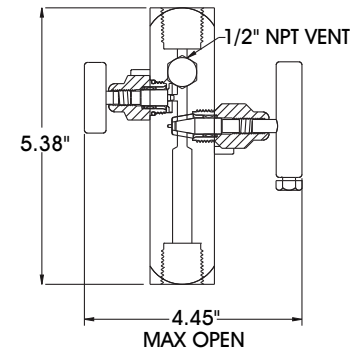

Above drawings shown with P9 Pipe Plug Option.

MATERIALS OF CONSTRUCTION

SEAT	MAX Cv RATINGS
Hard Ball	.53
Soft Cone	.83
Approx. Manifold Weight:	3.0 lbs each [V-626 / 627] 2.4 lbs each [V-614 / 615]

PART DESCRIPTION	CARBON STEEL	A105 CARBON STEEL	316 SS	MONEL®	HASTELLOY-C®
Body	ASTM A108-1215	ASTM A105-CF	ASTM A479-316	ASTM B164-N04405	ASTM B574-N10276
Bonnet	ASTM A108-1215	ASTM A479-316	ASTM A479-316	ASTM B164-N04405	ASTM B574-N10276
Stem	ASTM A582-303	ASTM A479-316	ASTM A479-316	ASTM B164-N04405	ASTM B574-N10276
Seal Retainer	ASTM A479-316	ASTM A479-316	ASTM A479-316	ASTM B164-N04405	ASTM B574-N10276
Handle Assembly	ASTM A108	ASTM A108	ASTM A582 (18-8)	ASTM A582 (18-8)	ASTM A582 (18-8)
Plug(s)	ASTM A108-1215	ASTM F593 (18.8)	ASTM A182-F (18-8)	ASTM B164-N04405	ASTM B574-N10276

- Carbon Steel Manifolds are Zinc Cobalt Plated with Dichromate Dip
- 316 SS Manifolds Meet NACE MR0175 Requirements (Latest Revision)
- 100% Pressure Tested
- Carbon Steel Weld End Connection Bodies are AISI 1018



Two-Valve Block & Bleed Manifolds

.187" ORIFICE

TWO-VALVE BLOCK & BLEED MANIFOLDS

ORDERING INFORMATION

BODY STYLE	BODY CODE	SEAT CODE	STEM SEAL CODE	OPTION CODES
Hard Seat				
V - 6 1 4			-	
V - 6 2 6			-	
Soft Seat				
V - 6 1 5			-	
V - 6 2 7			-	

BODY CODE	
[Std.] Carbon Steel	C
A105 Carbon Steel	P
[Std.] 316 SS	S
Monel®	M
Hastelloy-C®	H

HARD SEAT CODE	
[Std.] Carbide Ball	C
Ceramic Ball	R
316 SS Ball	6
Hastelloy-C® Ball	H
K-Monel® Ball	N

SOFT SEAT CODE	
Delrin® Cone / Washer [Std.]	D
Kel-F® Cone / Washer	K
PEEK® Cone / Washer	P
Teflon® Cone / Washer	T
Tefzel Cone / Washer	Z

STEM SEAL CODE	
[Std.] Teflon® Pressure-Core™	T
Grafoil® Packed	G
Teflon® Packed [Hard Seat Only]	P
Viton® O-Ring	V
Low-Temp Pressure-Core™	J

OPTIONS

- **Bonnet Handle Lock-Out**
- Bonnet Lock Plates

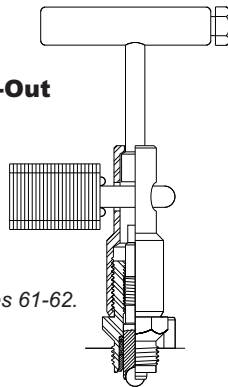

See Options/Accessories Pages 61-62.

OPTION CODE	OPTION DESCRIPTION
AM7	½" Male Pipe Socket Weld (Process Port)
GA	Anti-Tamper Bonnet (All Positions - Hard Seats Only)
GC	Anti-Tamper Bonnet (Isolate Valve Only)
GE	Anti-Tamper Bonnet (Vent Valve Only - Hard Seats Only)
GJ	Bonnet Lock-Out (All Positions - Lock Not Provided - Hard Seats Only)
GK	Bonnet Lock-Out (Isolate Valve Only - Lock Not Provided)
GM	Bonnet Lock-Out (Vent Valve Only - Lock Not Provided - Hard Seats Only)
P9	¼" Hex Head Pipe Plug in Vent/Test Port
TH	Hydrostatic Testing
W	Safety Bonnet Lock Plate
WK	Paper Tag
W1	316 SS Tag (20 Characters ~ See page 61)
XL	Clean for Critical Service (Oxygen or Chlorine)

PRESSURE & TEMPERATURE

BODY MATERIAL	HARD SEAT	HARD SEAT
	Teflon Pressure-Core	Grafoil
Carbon Steel Code C	10,000 PSI @ 200° F 8,000 PSI @ 450° F	Not Available.
A105 Carbon Steel Code P	10,000 PSI @ 200° F 8,000 PSI @ 450° F	6,000 PSI @ 200° F 1,500 PSI @ 800° F
316 SS Code S	10,000 PSI @ 200° F 8,000 PSI @ 450° F	6,000 PSI @ 200° F 1,500 PSI @ 1,000° F
See Page 5:	Chart D	Chart F
BODY MATERIAL	SOFT SEAT (Delrin)	SOFT SEAT (Peek)
	Teflon Pressure-Core	Teflon Pressure-Core
Carbon Steel Code C	6,000 PSI @ 200° F Max.	10,000 PSI @ 200° F 3,000 PSI @ 400° F
316 SS Code S	6,000 PSI @ 200° F Max.	10,000 PSI @ 200° F 3,000 PSI @ 400° F
See Page 5:	Chart B	Chart B

Two-Valve Stabilized Block & Bleed Manifolds

.187" ORIFICE

Description

MNPT x 1/2" MNPT

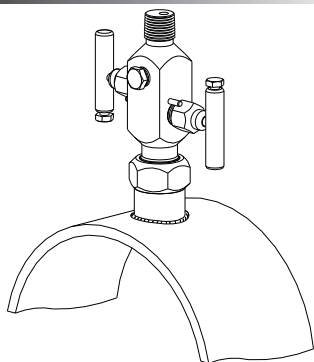

MNPT x 1/2" FNPT

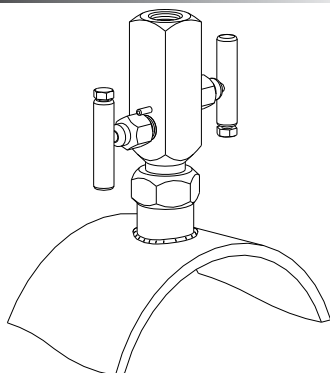

1/2" MNPT x (3) 1/2" FNPT

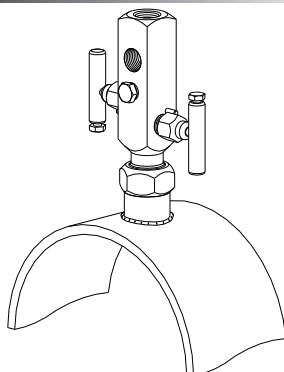

Body Style

V-700 Hard Seat

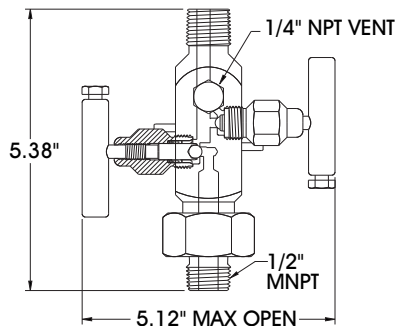

V-702 Hard Seat

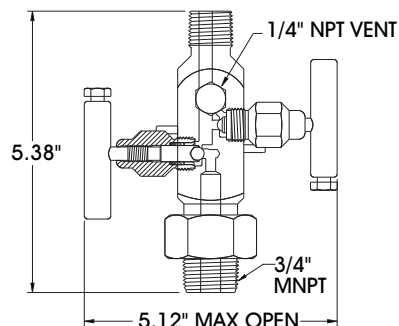

V-704 Hard Seat

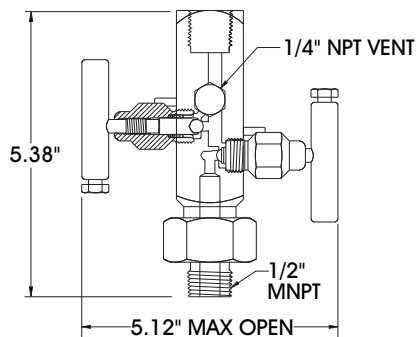

V-706 Hard Seat

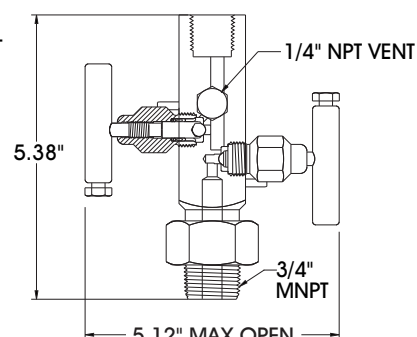

V-708 Hard Seat

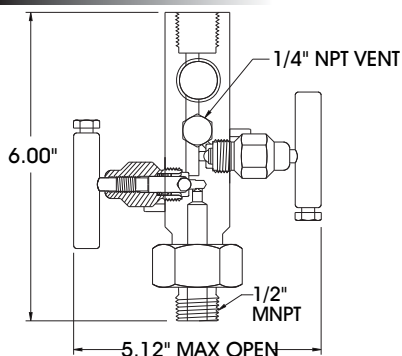

All drawings shown with P9 Pipe Plug Option.

SEAT	MAX Cv RATINGS
Hard Ball	.53
Approx. Manifold Weight:	3.0 lbs each [V-700 / 702 / 704 / 706] 3.5 lbs each [V-708]

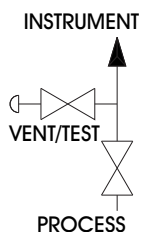

MATERIALS OF CONSTRUCTION

PART DESCRIPTION	CARBON STEEL	316 SS	MONEL®	HASTELLOY-C®
Body		ASTM A479-316		
Bonnet		ASTM A479-316		
Stem	Manifold not available in Carbon Steel.	ASTM A479-316	Consult Factory.	Consult Factory.
Seal Retainer		ASTM A479-316		
Handle Assembly		ASTM A582 (18-8)		
Plug(s)		ASTM A182-F (18-8)		

- Carbon Steel Manifolds are Zinc Cobalt Plated with Dichromate Dip
- 316 SS Manifolds Meet NACE MR0175 Requirements (Latest Revision)
- 100% Pressure Tested
- Carbon Steel Weld End Connection Bodies are AISI 1018

Two-Valve Stabilized Block & Bleed Manifolds

.187" ORIFICE

TWO-VALVE BLOCK & BLEED MANIFOLDS

ORDERING INFORMATION

BODY STYLE	BODY CODE	SEAT CODE	STEM SEAL CODE	OPTION CODES
Hard Seat				
V-700			-	
V-702			-	
V-704			-	
V-706			-	
V-708			-	

BODY CODE	
[Std.] 316 SS	S
Monel®	M
Hastelloy-C®	H

HARD SEAT CODE	
C	Carbide Ball [Std.]
R	Ceramic Ball
6	316 SS Ball

STEM SEAL CODE	
[Std.] Teflon® Pressure-Core™	T
Grafoil® Packed	G
Teflon® Packed	P
Viton® O-Ring	V
Low-Temp Pressure-Core™	J

OPTION CODE	OPTION DESCRIPTION
GA	Anti-Tamper Bonnet (All Positions - Hard Seats Only)
GC	Anti-Tamper Bonnet (Isolate Valve Only)
GE	Anti-Tamper Bonnet (Vent Valve Only - Hard Seats Only)
GJ	Bonnet Lock-Out (All Positions - Lock Not Provided - Hard Seats Only)
GK	Bonnet Lock-Out (Isolate Valve Only - Lock Not Provided)
GM	Bonnet Lock-Out (Vent Valve Only - Lock Not Provided - Hard Seats Only)
P9	¼" Hex Head Pipe Plug in Vent/Test Port
TH	Hydrostatic Testing
W	Safety Bonnet Lock Plate
WK	Paper Tag
W1	316 SS Tag (20 Characters ~ See page 61)
XL	Clean for Critical Service (Oxygen or Chlorine)

OPTIONS

- **Versa-Mount Brackets**
- Bonnet Handle Lock-Out
- Bonnet Lock Plates
- Integral Tube Fitting Connections

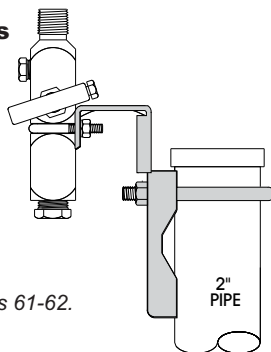

See Options/Accessories Pages 61-62.

PRESSURE & TEMPERATURE

BODY MATERIAL	HARD SEAT	HARD SEAT
	Teflon Pressure-Core	Grafoil
316 SS	10,000 PSI @ 200° F	6,000 PSI @ 200° F
	8,000 PSI @ 450° F	1,500 PSI @ 1,000° F
See Page 5:	Chart D	Chart F

Three-Valve Double Block & Bleed Manifolds

.187" ORIFICE

Description

1/2" MNPT x 1/2" FNPT

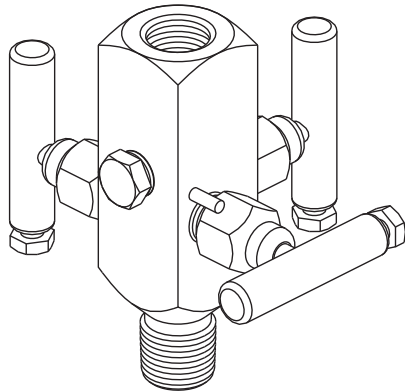

Body Style

V-690 Hard Seat

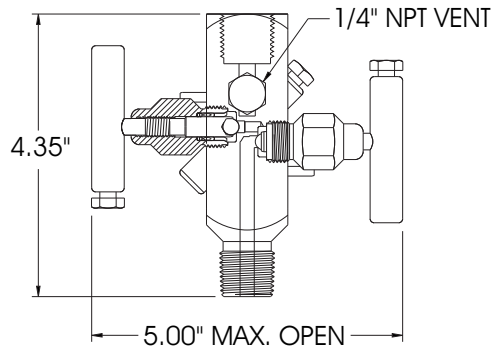

3/4" MNPT x 1/2" FNPT

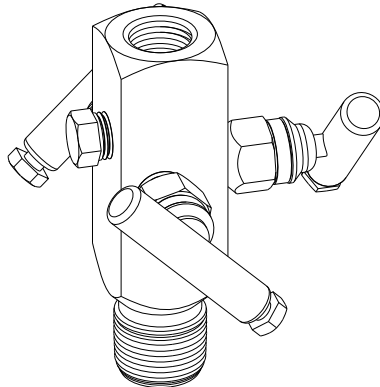

V-692 Hard Seat

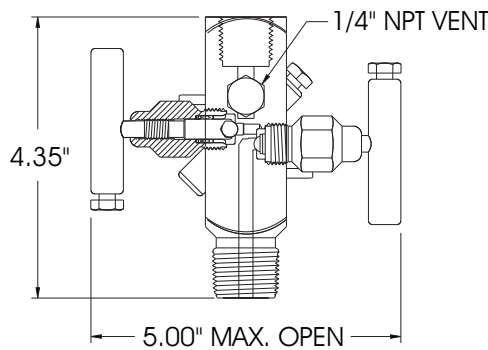

Above drawings shown with P9 Pipe Plug Option.

SEAT	MAX Cv RATINGS
Hard Ball	.53
Soft Cone	.83
Approx. Manifold Weight: 3.0 lbs each [V-690 / 692]	

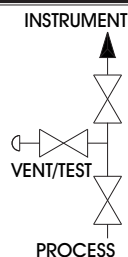

MATERIALS OF CONSTRUCTION

PART DESCRIPTION	CARBON STEEL	316 SS	MONEL®	HASTELLOY-C®
Body		ASTM A479-316		
Bonnet		ASTM A479-316		
Stem	Consult Factory.	ASTM A479-316	Consult Factory.	Consult Factory.
Seal Retainer		ASTM A479-316		
Handle Assembly		ASTM A582 (18-8)		
Plug(s)		ASTM A182-F (18-8)		

- Carbon Steel Manifolds are Zinc Cobalt Plated with Dichromate Dip
- 316 SS Manifolds Meet NACE MR0175 Requirements (Latest Revision)
- 100% Pressure Tested
- Carbon Steel Weld End Connection Bodies are AISI 1018

Three-Valve Double Block & Bleed Manifolds

.187" ORIFICE

THREE-VALVE BLOCK & BLEED MANIFOLDS

ORDERING INFORMATION

BODY STYLE	BODY CODE	SEAT CODE	STEM SEAL CODE	OPTION CODES
Hard Seat				
V-690			-	
V-692			-	

BODY CODE
[Std.] 316 SS S

HARD SEAT CODE	DESCRIPTION
C	Carbide Ball [Std.]
R	Ceramic Ball
6	316 SS Ball

STEM SEAL CODE	DESCRIPTION
[Std.] Teflon® Pressure-Core™	T
Grafoil® Packed	G
Teflon® Packed	P
Viton® O-Ring	V
Low-Temp Pressure-Core™	J

OPTIONS

- **Bonnet Handle Lock-Out**
- Bonnet Lock Plates

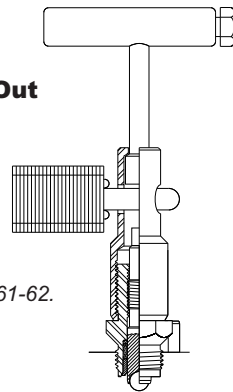

See Options/Accessories Pages 61-62.

OPTION CODE	OPTION DESCRIPTION
AM7	1/2" Male Pipe Socket Weld (Process Port)
GA	Anti-Tamper Bonnet (All Positions)
GC	Anti-Tamper Bonnet (Isolate Only)
GE	Anti-Tamper Bonnet (Vent Valve Only)
GJ	Bonnet Lock-Out (All Positions - Lock Not Provided)
GK	Bonnet Lock-Out (Isolate Only - Lock Not Provided)
GM	Bonnet Lock-Out (Vent Valve Only - Lock Not Provided)
P9	1/4" Hex Head Pipe Plug in Vent/Test Port
TH	Hydrostatic Testing
W	Safety Bonnet Lock Plate
WK	Paper Tag
W1	316 SS Tag (20 Characters ~ See page 61)
XL	Clean for Critical Service (Oxygen or Chlorine)

PRESSURE & TEMPERATURE

BODY MATERIAL	HARD SEAT	HARD SEAT
	Teflon Pressure-Core	Grafoil
316 SS	10,000 PSI @ 200° F	6,000 PSI @ 200° F
	8,000 PSI @ 450° F	1,500 PSI @ 1,000° F
See Page 5:	Chart D	Chart F

Two-Valve Versa-Mount Block & Bleed Manifolds

.187" ORIFICE

Description

(2) 1/2" FNPT x 1/2" MNPT

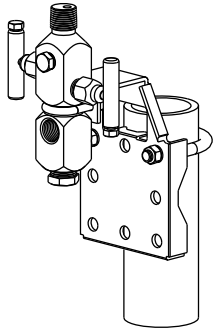

(2) 1/2" FNPT x 1/2" FNPT

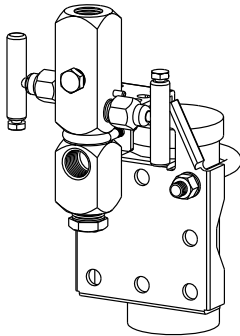

1/2" FNPT x 1/2" MNPT

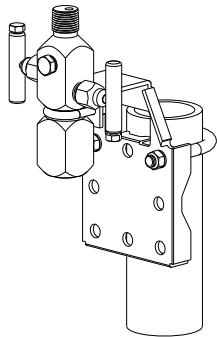

Body Style

V-620 Hard Seat

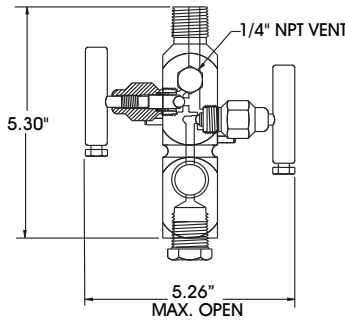

V-621 Soft Seat

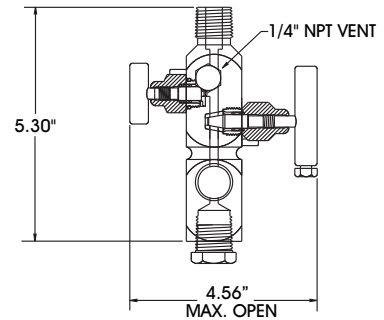

V-622 Hard Seat

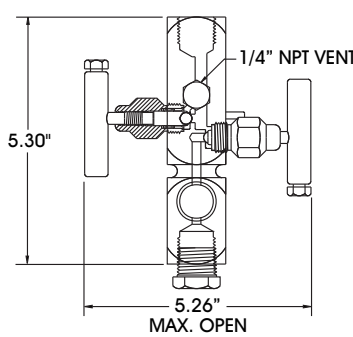

V-623 Soft Seat

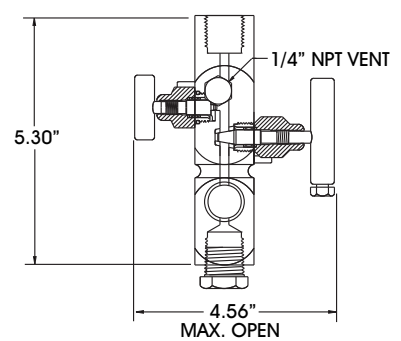

V-624 Hard Seat

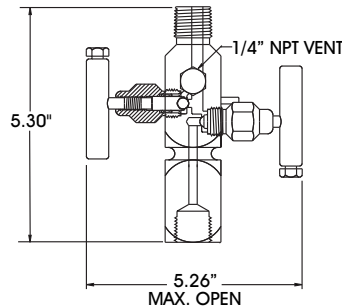

V-625 Soft Seat

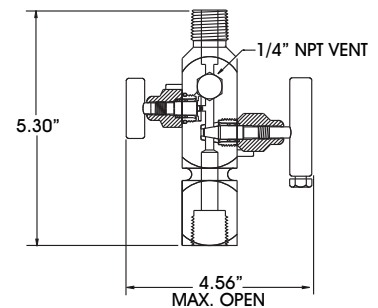

Above drawings shown with P9 Pipe Plug Option.

MATERIALS OF CONSTRUCTION

SEAT	MAX Cv RATINGS
Hard Ball	.53

PART DESCRIPTION	CARBON STEEL	A105 CARBON STEEL	316 SS	MONEL®	HASTELLOY-C®
Body	ASTM A108-1215	ASTM A105-CF	ASTM A479-316	ASTM B164-N04405	ASTM B574-N10276
Bonnet	ASTM A108-1215	ASTM A479-316	ASTM A479-316	ASTM B164-N04405	ASTM B574-N10276
Stem	ASTM A582-303	ASTM A479-316	ASTM A479-316	ASTM B164-N04405	ASTM B574-N10276
Seal Retainer	ASTM A479-316	ASTM A479-316	ASTM A479-316	ASTM B164-N04405	ASTM B574-N10276
Handle Assembly	ASTM A108	ASTM A108	ASTM A582 (18-8)	ASTM A582 (18-8)	ASTM A582 (18-8)
Plug(s)	ASTM A108	ASTM F593 (18.8)	ASTM A182-F (18-8)	ASTM B164-N04405	ASTM B574-N10276
U-Bolts	300 SERIES SS	300 SERIES SS	300 SERIES SS	300 SERIES SS	300 SERIES SS

- Carbon Steel Manifolds are Zinc Cobalt Plated with Dichromate Dip
- 316 SS Manifolds Meet NACE MR0175 Requirements (Latest Revision)
- 100% Pressure Tested
- Carbon Steel Weld End Connection Bodies are AISI 1018

V-620 & V-622

INSTRUMENT

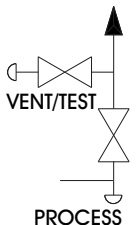

V-624

INSTRUMENT

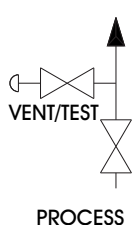

Two-Valve Versa-Mount Block & Bleed Manifolds

.187" ORIFICE

TWO-VALVE VERSA-MOUNT MANIFOLDS

ORDERING INFORMATION

BODY STYLE	BODY CODE	SEAT CODE	STEM SEAL CODE	OPTION CODES
Hard Seat				
V - 6 2 0			-	
V - 6 2 2			-	
V - 6 2 4			-	
Soft Seat				
V - 6 2 1			-	
V - 6 2 3			-	
V - 6 2 5			-	

BODY CODE	
[Std.] Carbon Steel	C
A105 Carbon Steel	P
[Std.] 316 SS	S
Monel®	M
Hastelloy-C®	H

HARD SEAT CODE	
[Std.] Carbide Ball	C
Ceramic Ball	R
316 SS Ball	6
Hastelloy-C® Ball	H
K-Monel® Ball	N

SOFT SEAT CODE	
Delrin® Cone / Washer [Std.]	D
Kel-F® Cone / Washer	K
PEEK® Cone / Washer	P
Teflon® Cone / Washer	T
Tefzel Cone / Washer	Z

STEM SEAL CODE	
[Std.] Teflon® Pressure-Core™	T
Grafoil® Packed	G
Teflon® Packed [Hard Seat Only]	P
Viton® O-Ring	V
Low-Temp Pressure-Core™	J

OPTIONS

- **Versa-Mount Brackets**
- Bonnet Handle Lock-Out
- Bonnet Lock Plates
- Integral Tube Fitting Connections

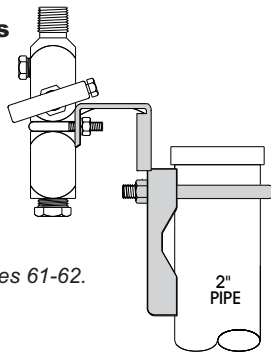

See Options/Accessories Pages 61-62.

OPTION CODE	OPTION DESCRIPTION
AU7	½" Integral Tube Fitting - Parker® A-LOK Dual Ferrules (Process Ports)
AV7	½" Integral Tube Fitting - Swagelok® Dual Ferrules (Process Ports)
GA	Anti-Tamper Bonnet (All Positions)
GC	Anti-Tamper Bonnet (Isolate Valve(s) Only)
GE	Anti-Tamper Bonnet (Vent Valve(s) Only)
GJ	Bonnet Lock-Out (All Positions - Lock Not Provided)
GK	Bonnet Lock-Out (Isolate Valve(s) Only - Lock Not Provided)
GM	Bonnet Lock-Out (Vent Valve(s) Only - Lock Not Provided)
P9	¼" Hex Head Pipe Plug in Vent/Test Port
TH	Hydrostatic Testing
VC	CS Versa-Mount Bracket
VS	316 SS Versa-Mount Bracket
VCH	CS Heavy-Duty Versa-Mount Bracket
VSH	316 SS Heavy-Duty Versa-Mount Bracket
W	Safety Bonnet Lock Plate
WK	Paper Tag
W1	316 SS Tag (20 Characters ~ See page 61)
XL	Clean for Critical Service (Oxygen or Chlorine)

PRESSURE & TEMPERATURE

BODY MATERIAL	HARD SEAT	HARD SEAT
	Teflon Pressure-Core	Grafoil
Carbon Steel Code C	10,000 PSI @ 200° F 8,000 PSI @ 450° F	Not Available.
A105 Carbon Steel Code P	10,000 PSI @ 200° F 8,000 PSI @ 450° F	6,000 PSI @ 200° F 1,500 PSI @ 800° F
316 SS Code S	10,000 PSI @ 200° F 8,000 PSI @ 450° F	6,000 PSI @ 200° F 1,500 PSI @ 1,000° F
See Page 5:	Chart D	Chart F

Two-Valve Block & Bleed Manifolds

.136" ORIFICE

Description

1/2" FNPT x 1/2" FNPT

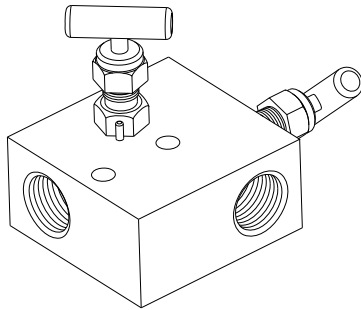

Body Style

M-507 Hard Seat

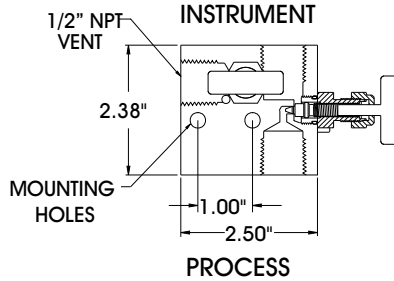

M-507 Soft Seat

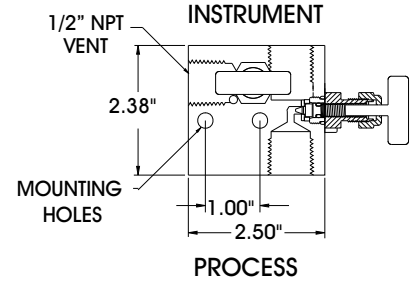

1/4" FNPT x 1/4" FNPT

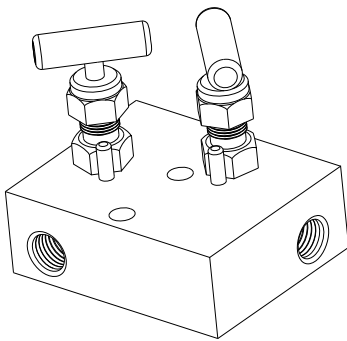

M-508 Hard Seat

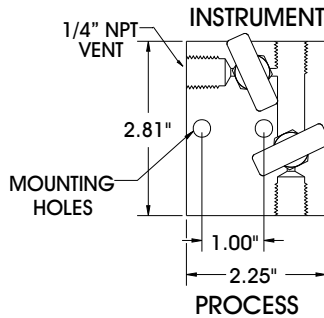

M-508 Soft Seat

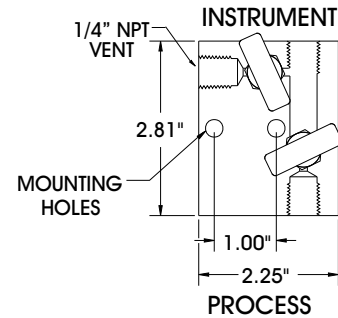

SEAT	MAX Cv RATINGS
Integral Metal	.25
Soft Washer	.22
Approx. Manifold Weight:	2.7 lbs each [M-507] 2.4 lbs each [M-508]

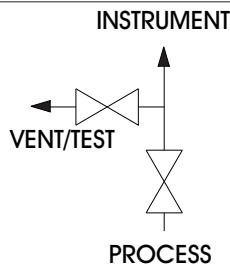

MATERIALS OF CONSTRUCTION

PART DESCRIPTION	CARBON STEEL	316 SS	MONEL®	HASTELLOY-C®
Body	ASTM A108-1215	ASTM A479-316	Manifold not available in Monel®.	Manifold not available in Hastelloy-C®.
Bonnet	ASTM A108-1215	ASTM A479-316		
Stem	ASTM A582-303	ASTM A479-316		
Seal Retainer	---	---		
Handle Assembly	ASTM A108	ASTM A582 (18-8)		
Plug(s)	---	---		
Mounting Bolts	---	---		

- Carbon Steel Manifolds are Zinc Cobalt Plated with Dichromate Dip
- 316 SS Manifolds Meet NACE MR0175 Requirements (Latest Revision)
- 100% Pressure Tested
- Carbon Steel Weld End Connection Bodies are AISI 1018

Two-Valve Block & Bleed Manifolds

.136" ORIFICE

TWO-VALVE BLOCK & BLEED MANIFOLDS

ORDERING INFORMATION

BODY STYLE	BODY CODE	SEAT CODE	STEM SEAL CODE	OPTION CODES
Hard Seat				
M - 507			-	
M - 508			-	
Soft Seat				
M - 507			-	
M - 508			-	

BODY CODE	
[Std.] Carbon Steel	C
[Std.] 316 SS	S

HARD SEAT CODE	
[Std.] Integral Metal	M

SOFT SEAT CODE	
D	Delrin® Washer [Std.]
K	Kel-F® Washer
P	PEEK® Washer
T	Teflon® Washer
Z	Tefzel Washer

STEM SEAL CODE	
[Std.] Teflon® Packed	T
Grafoil® Packed	G
Viton® O-Ring	V

OPTIONS

- **Versa-Mount Brackets**

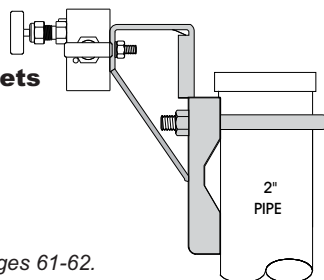

See Options/Accessories Pages 61-62.

OPTION CODE	OPTION DESCRIPTION
H5	CS Mini Round Handles
H6	SS Mini Round Handles
TH	Hydrostatic Testing
VC	CS Versa-Mount Bracket
VS	316 SS Versa-Mount Bracket
WK	Paper Tag
W1	316 SS Tag (20 Characters ~ See page 61)
XL	Clean for Critical Service (Oxygen or Chlorine)

PRESSURE & TEMPERATURE

BODY MATERIAL	METAL SEAT	METAL SEAT
	Teflon Packed or Viton O-ring	Grafoil Packed
Carbon Steel	6,000 PSI @ 200° F Max.	2,000 PSI @ 450° F Max.
316 SS	4,000 PSI @ 450° F Max.	2,000 PSI @ 450° F Max.
See Page 5:	Chart C	Chart F
BODY MATERIAL	SOFT SEAT (Delrin)	SOFT SEAT (Peek)
	Teflon Packed or Viton O-ring	Teflon Packed or Viton O-ring
Carbon Steel	3,000 PSI @ 200° F Max.	6,000 PSI @ 200° F Max.
316 SS	3,000 PSI @ 200° F Max.	6,000 PSI @ 200° F Max.
See Page 5:	Chart C	Chart C

Two-Valve Block & Bleed Manifolds

.187" ORIFICE

Description

1/2" FNPT x 1/2" FNPT

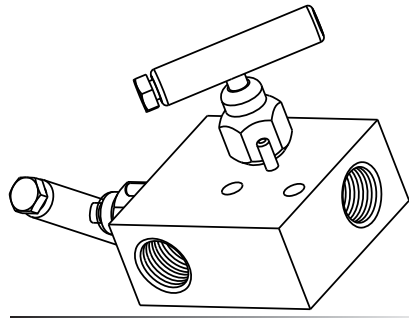

Body Style M-518 Hard Seat

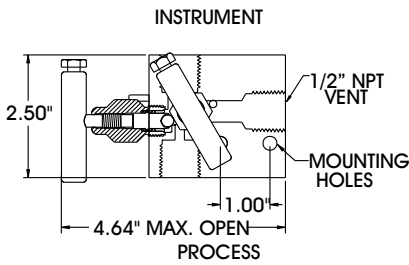

M-517 Soft Seat

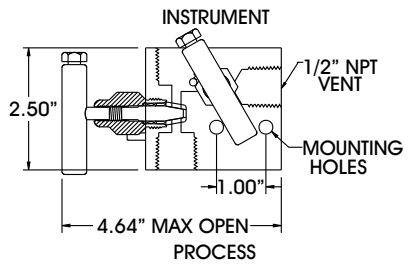

1/2" FNPT x Flange

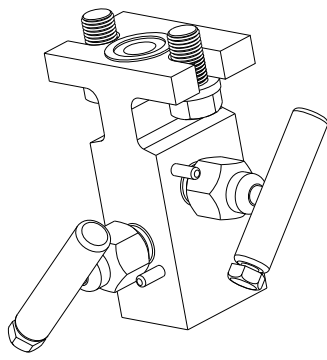

Slim Body Style M-616 Hard Seat

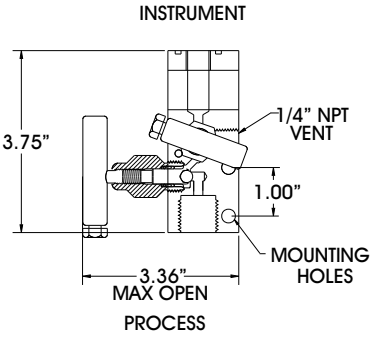

M-615 Soft Seat

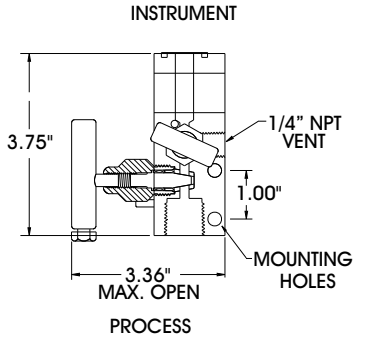

Flange x Flange

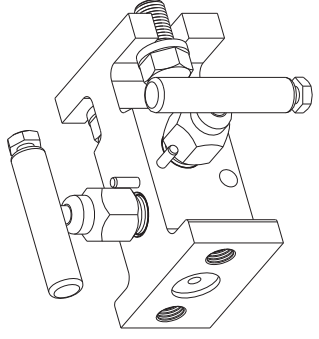

Slim Body Style M-716 Hard Seat

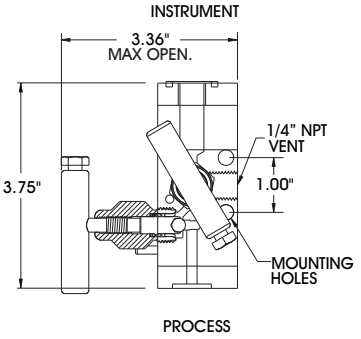

M-715 Soft Seat

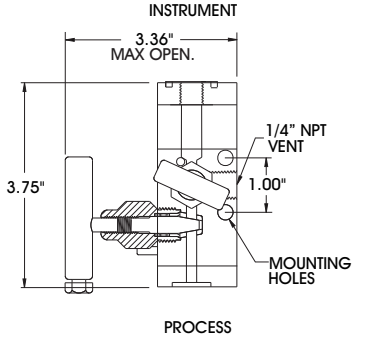

MATERIALS OF CONSTRUCTION

SEAT	MAX Cv RATINGS
Hard Ball	.53
Soft Cone	.83
Approx. Manifold Weight:	3.1 lbs each [M-517 / 518]
	2.6 lbs each [M-615 / 616]
	3.0 lbs each [M-715 / 716]

PART DESCRIPTION	CARBON STEEL	A105 CARBON STEEL	316 SS	MONEL®	HASTELLOY-C®
Body	ASTM A108-1215	ASTM A105-CF	ASTM A479-316	ASTM B164-N04405 or ASTM B164-N04400	ASTM B575-N10276 or ASTM A494 CW-12MW
Bonnet	ASTM A108-1215	ASTM A479-316	ASTM A479-316	ASTM B164-N04405	ASTM B574-N10276
Stem	ASTM A582-303	ASTM A479-316	ASTM A479-316	ASTM B164-N04405	ASTM B574-N10276
Seal Retainer	ASTM A479-316	ASTM A479-316	ASTM A479-316	ASTM B164-N04405	ASTM B574-N10276
Handle Assembly	ASTM A108	ASTM A108	ASTM A582 (18-8)	ASTM A582 (18-8)	ASTM A582 (18-8)
Plug(s)	ASTM A108	ASTM F593 (18.8)	ASTM A182-F (18-8)	ASTM B164-N04405	ASTM B574-N10276
Mounting Bolts	ASTM A449-TYPE 1	ASTM A449-TYPE 1	ASTM A449-TYPE 1	ASTM F593 (18-8)	ASTM F593 (18-8)

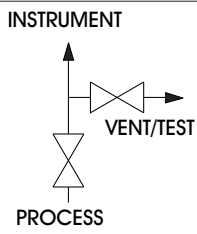

- Carbon Steel Manifolds are Zinc Cobalt Plated with Dichromate Dip
- 316 SS Manifolds Meet NACE MR0175 Requirements (Latest Revision)
- 100% Pressure Tested
- Carbon Steel Weld End Connection Bodies are AISI 1018

Two-Valve Block & Bleed Manifolds

.187" ORIFICE

TWO-VALVE BLOCK & BLEED MANIFOLDS

ORDERING INFORMATION

BODY STYLE	BODY CODE	SEAT CODE	STEM SEAL CODE	OPTION CODES
Hard Seat				
M - 5 1 8			-	
M - 6 1 6			-	
M - 7 1 6			-	
Soft Seat				
M - 5 1 7			-	
M - 6 1 5			-	
M - 7 1 5			-	

BODY CODE	
[Std.] Carbon Steel	C
A105 Carbon Steel	P
[Std.] 316 SS	S
Monel®	M
Hastelloy-C®	H

HARD SEAT CODE		SOFT SEAT CODE	
[Std.] Carbide Ball	C	D	Delrin® Cone [Std.]
Ceramic Ball	R	K	Kel-F® Cone
316 SS Ball	6	P	Peek® Cone
K-Monel®	N	T	Teflon® Cone
Hastelloy-C®	H	Z	Tefzel Cone

STEM SEAL CODE	
[Std.] Teflon® Pressure-Core™	T
Grafoil® Packed	G
Viton® O-Ring	V
Low-Temp Pressure-Core™	J
Teflon® Packed [Hard Seat Only]	P

OPTIONS

- **Bonnet Lock Plates**
- Versa-Mount Brackets
- Bonnet Handle Lock-Out
- Steam Trace Block
- Integral Tube Fitting Connections

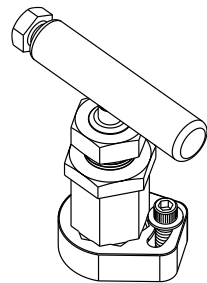

See Options/Accessories Pages 61-62.

OPTION CODE	OPTION DESCRIPTION
AU7	½" Integral Tube Fitting - Parker® A-LOK Dual Ferrules (Process Ports)
AV7	½" Integral Tube Fitting - Swagelok® Dual Ferrules (Process Ports)
GA	Anti-Tamper Bonnet (All Positions)
GC	Anti-Tamper Bonnet (Isolate Valve(s) Only)
GE	Anti-Tamper Bonnet (Vent Valve(s) Only)
GJ	Bonnet Lock-Out (All Positions - Lock Not Provided)
GK	Bonnet Lock-Out (Isolate Valve(s) Only - Lock Not Provided)
GM	Bonnet Lock-Out (Vent Valve(s) Only - Lock Not Provided)
ME	Slotted Instrument Flange Using Bolts over 3"
MH	Viton® O-Ring Flange Seals
MU	Dielectric Isolation (Flange Manifolds Only)
TC	Steam Trace Block - Carbon Steel
TH	Hydrostatic Testing
TS	Steam Trace Block - 316 SS
VC	CS Versa-Mount Bracket
VS	316 SS Versa-Mount Bracket
VCH	CS Heavy-Duty Versa-Mount Bracket
VSH	316 SS Heavy-Duty Versa-Mount Bracket
W	Safety Bonnet Lock Plate
WA	CS
WAW3	300 SS
WAW9	316 SS
WK	Paper Tag
W1	316 SS Tag (20 Characters ~ See page 61)
W3	300 SS Standard Length Flange Bolts (CS Standard)
W9	316 SS Standard Length Flange Bolts (CS Standard)
XL	Clean for Critical Service (Oxygen or Chlorine)

PRESSURE & TEMPERATURE

BODY MATERIAL	HARD SEAT	
	Teflon Pressure-Core	Grafoil
Carbon Steel Code C	10,000 PSI @ 200° F 8,000 PSI @ 450° F	Not Available.
A105 Carbon Steel Code P	10,000 PSI @ 200° F 8,000 PSI @ 450° F	6,000 PSI @ 200° F 1,500 PSI @ 800° F
316 SS Code S	10,000 PSI @ 200° F 8,000 PSI @ 450° F	6,000 PSI @ 200° F 1,500 PSI @ 1,000° F
See Page 5:	Chart D	Chart F
BODY MATERIAL	SOFT SEAT	
	SOFT SEAT (Delrin) Teflon Pressure-Core	SOFT SEAT (Peek) Teflon Pressure-Core
Carbon Steel Code C	6,000 PSI @ 200° F Max.	10,000 PSI @ 200° F 3,000 PSI @ 400° F
316 SS Code S	6,000 PSI @ 200° F Max.	10,000 PSI @ 200° F 3,000 PSI @ 400° F
See Page 5:	Chart B	Chart B

Two-Valve Block & Bleed Manifolds

.187" ORIFICE

Description

1/2" FNPT x Flange

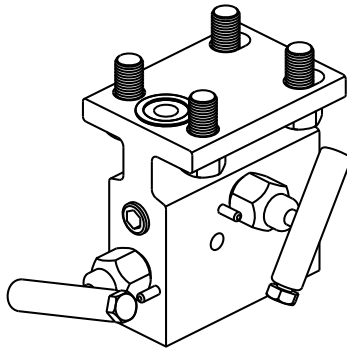

Body Style

M-618 Hard Seat

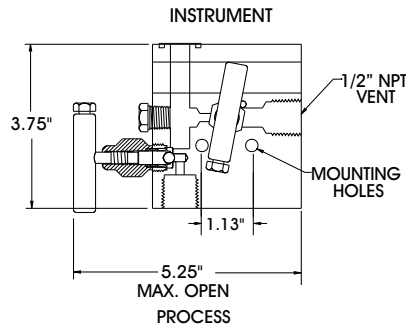

M-617 Soft Seat

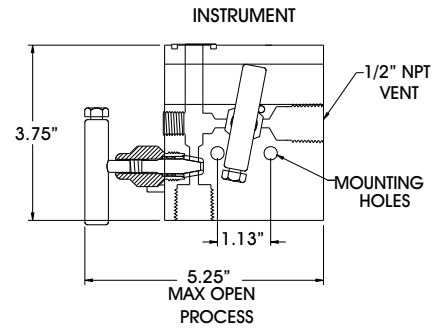

1/2" FNPT x Flange

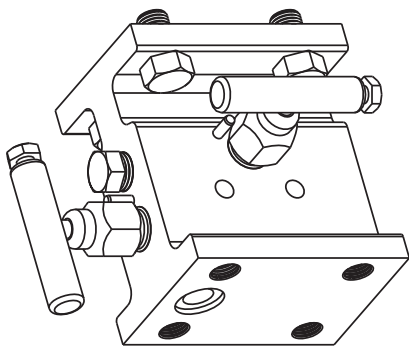

Slim Body Style

M-718 Hard Seat

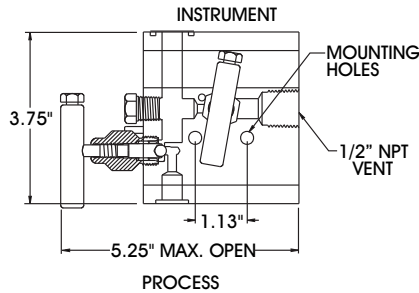

M-717 Soft Seat

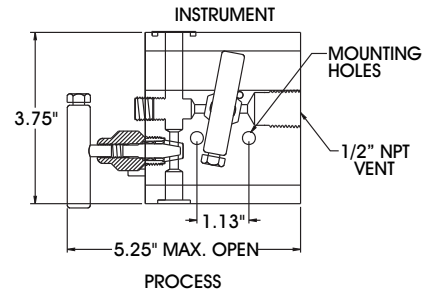

MATERIALS OF CONSTRUCTION

SEAT	MAX Cv RATINGS
Hard Ball	.53
Soft Cone	.83
Approx. Manifold Weight:	5.0 lbs each [M-617 / 618] 5.5 lbs each [M-717 / 718]

PART DESCRIPTION	CARBON STEEL	A105 CARBON STEEL	316 SS	MONEL®	HASTELLOY-C®
Body	ASTM A108-1215	ASTM A105-CF	ASTM A479-316	ASTM B164-N04405 or ASTM B164-N04400	ASTM B575-N10276 or ASTM A494 CW-12MW
Bonnet	ASTM A108-1215	ASTM A479-316	ASTM A479-316	ASTM B164-N04405	ASTM B574-N10276
Stem	ASTM A582-303	ASTM A479-316	ASTM A479-316	ASTM B164-N04405	ASTM B574-N10276
Seal Retainer	ASTM A479-316	ASTM A479-316	ASTM A479-316	ASTM B164-N04405	ASTM B574-N10276
Handle Assembly	ASTM A108	ASTM A108	ASTM A582 (18-8)	ASTM A582 (18-8)	ASTM A582 (18-8)
Plug(s)	ASTM A108	ASTM F593 (18.8)	ASTM A182-F (18-8)	ASTM B164-N04405	ASTM B574-N10276
Mounting Bolts	ASTM A449-TYPE 1	ASTM A449-TYPE 1	ASTM A449-TYPE 1	ASTM F593 (18-8)	ASTM F593 (18-8)

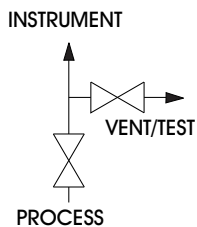

- Carbon Steel Manifolds are Zinc Cobalt Plated with Dichromate Dip
- 316 SS Manifolds Meet NACE MR0175 Requirements (Latest Revision)
- 100% Pressure Tested
- Carbon Steel Weld End Connection Bodies are AISI 1018

Two-Valve Block & Bleed Manifolds

.187" ORIFICE

TWO-VALVE BLOCK & BLEED MANIFOLDS

ORDERING INFORMATION

BODY STYLE	BODY CODE	SEAT CODE	STEM SEAL CODE	OPTION CODES
Hard Seat				
M - 6 1 8			-	
M - 7 1 8			-	
Soft Seat				
M - 6 1 7			-	
M - 7 1 7			-	

BODY CODE	
[Std.] Carbon Steel	C
A105 Carbon Steel	P
[Std.] 316 SS	S
Monel®	M
Hastelloy-C®	H

HARD SEAT CODE		SOFT SEAT CODE	
[Std.] Carbide Ball	C	D	Delrin® Cone [Std.]
Ceramic Ball	R	K	Kel-F® Cone
316 SS Ball	6	P	Peek® Cone
K-Monel®	N	T	Teflon® Cone
Hastelloy-C®	H	Z	Tefzel Cone

STEM SEAL CODE	
[Std.] Teflon® Pressure-Core™	T
Grafoil® Packed	G
Viton® O-Ring	V
Low-Temp Pressure-Core™	J
Teflon® Packed [Hard Seat Only]	P

OPTION CODE	OPTION DESCRIPTION
AU7	½" Integral Tube Fitting - Parker® A-LOK Dual Ferrules (Process Ports)
AV7	½" Integral Tube Fitting - Swagelok® Dual Ferrules (Process Ports)
GA	Anti-Tamper Bonnet (All Positions)
GC	Anti-Tamper Bonnet (Isolate Valve(s) Only)
GE	Anti-Tamper Bonnet (Vent Valve(s) Only)
GJ	Bonnet Lock-Out (All Positions - Lock Not Provided)
GK	Bonnet Lock-Out (Isolate Valve(s) Only - Lock Not Provided)
GM	Bonnet Lock-Out (Vent Valve(s) Only - Lock Not Provided)
ME	Slotted Instrument Flange Using Bolts over 3"
MH	Viton® O-Ring Flange Seals
MU	Dielectric Isolation (Flange Manifolds Only)
TC	Steam Trace Block - Carbon Steel
TH	Hydrostatic Testing
TS	Steam Trace Block - 316 SS
VC	CS Versa-Mount Bracket
VS	316 SS Versa-Mount Bracket
VCH	CS Heavy-Duty Versa-Mount Bracket
VSH	316 SS Heavy-Duty Versa-Mount Bracket
W	Safety Bonnet Lock Plate
WA	CS
WAW3	300 SS
WAW9	316 SS
WK	Paper Tag
W1	316 SS Tag (20 Characters - See page 61)
W3	300 SS Standard Length Flange Bolts (CS Standard)
W9	316 SS Standard Length Flange Bolts (CS Standard)
XL	Clean for Critical Service (Oxygen or Chlorine)

OPTIONS

- **Bonnet Lock Plates**
- Versa-Mount Brackets
- Bonnet Handle Lock-Out
- Steam Trace Block
- Integral Tube Fitting Connections

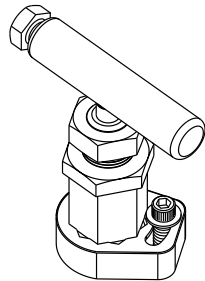

See Options/Accessories Pages 61-62.

PRESSURE & TEMPERATURE

BODY MATERIAL	HARD SEAT	
	Teflon Pressure-Core	Grafoil
Carbon Steel Code C	10,000 PSI @ 200° F 8,000 PSI @ 450° F	Not Available.
A105 Carbon Steel Code P	10,000 PSI @ 200° F 8,000 PSI @ 450° F	6,000 PSI @ 200° F 1,500 PSI @ 800° F
316 SS Code S	10,000 PSI @ 200° F 8,000 PSI @ 450° F	6,000 PSI @ 200° F 1,500 PSI @ 1,000° F
See Page 5:	Chart D	Chart F

BODY MATERIAL	SOFT SEAT (Delrin)		SOFT SEAT (Peek)	
	Teflon Pressure-Core		Teflon Pressure-Core	
Carbon Steel Code C	6,000 PSI @ 200° F Max.		10,000 PSI @ 200° F 3,000 PSI @ 400° F	
316 SS Code S	6,000 PSI @ 200° F Max.		10,000 PSI @ 200° F 3,000 PSI @ 400° F	
See Page 5:	Chart B		Chart B	

Two-Valve Block & Bleed Manifolds

.250" ORIFICE

Description

1/2" FNPT x 1/2" FNPT

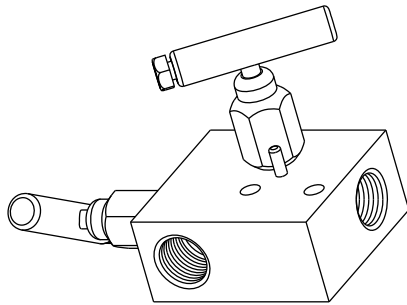

Body Style

M2-517 Soft Seat

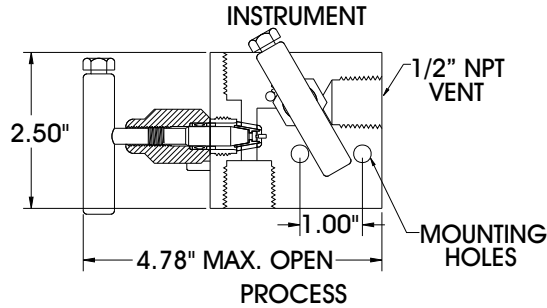

1/2" FNPT x Flange

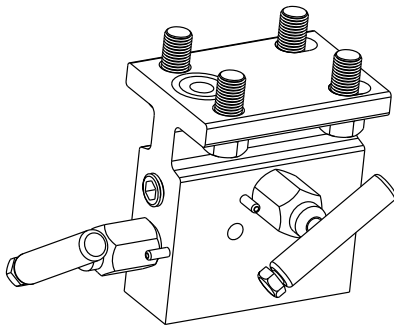

M2-617 Soft Seat

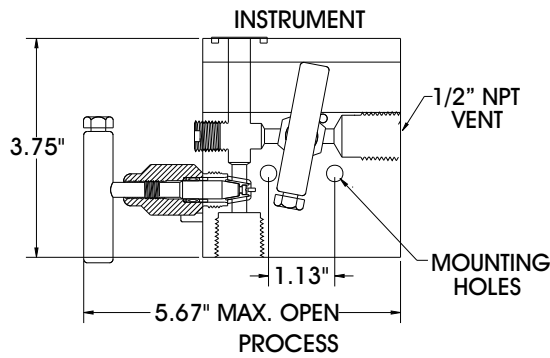

SEAT	MAX Cv RATINGS
Soft Cone	.83
Approx. Manifold Weight:	3.1 lbs each [M2-517] 5.1 lbs each [M2-617]

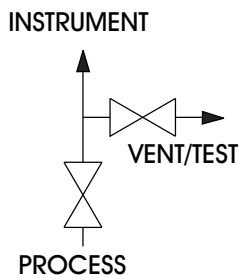

MATERIALS OF CONSTRUCTION

PART DESCRIPTION	CARBON STEEL	316 SS	MONEL®	HASTELLOY-C®
Body	ASTM A108-1215	ASTM A479-316	ASTM B164-N04405 or ASTM B164-N04400	ASTM B574-N10276 or ASTM A494 CW-12MW
Bonnet	ASTM A108-1215	ASTM A479-316	ASTM B164-N04405	ASTM B574-N10276
Stem	ASTM A582-303	ASTM A479-316	ASTM B164-N04405	ASTM B574-N10276
Seal Retainer	ASTM A479-316	ASTM A479-316	ASTM B164-N04405	ASTM B574-N10276
Handle Assembly	ASTM A108	ASTM A582 (18-8)	ASTM A582 (18-8)	ASTM A582 (18-8)
Plug(s)	ASTM A108	ASTM A182-F (18-8)	ASTM B164-N04405	ASTM B574-N10276
Mounting Bolts	ASTM A449-TYPE 1	ASTM A449-TYPE 1	ASTM F593 (18-8)	ASTM F593 (18-8)

- Carbon Steel Manifolds are Zinc Cobalt Plated with Dichromate Dip
- 316 SS Manifolds Meet NACE MR0175 Requirements (Latest Revision)
- 100% Pressure Tested
- Carbon Steel Weld End Connection Bodies are AISI 1018

Two-Valve Block & Bleed Manifolds

.250" ORIFICE

TWO-VALVE BLOCK & BLEED MANIFOLDS

ORDERING INFORMATION

BODY STYLE	BODY CODE	SEAT CODE	STEM SEAL CODE	OPTION CODES
Soft Seat				
M 2 - 5 1 7			-	
M 2 - 6 1 7			-	

BODY CODE	
[Std.] Carbon Steel	C
[Std.] 316 SS	S
Monel®	M
Hastelloy-C®	H

SOFT SEAT CODE	
D	Delrin® Cone [Std.]
K	Kel-F® Cone
P	PEEK® Cone
T	Teflon® Cone
Z	Tefzel Cone

STEM SEAL CODE	
[Std.] Teflon® Pressure-Core™	T
Viton® O-Ring	V
Low-Temp Pressure-Core™	J

OPTIONS

- **Integral Tube Fitting Connections**
- Versa-Mount Brackets
- Bonnet Handle Lock-Out
- Bonnet Lock Plates

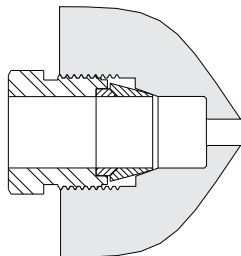

See Options/Accessories Pages 61-62.

PRESSURE & TEMPERATURE

BODY MATERIAL	SOFT SEAT (Delrin)	SOFT SEAT (Peek)
	Teflon Pressure-Core	Teflon Pressure-Core
Carbon Steel	6,000 PSI @ 200° F Max.	10,000 PSI @ 200° F 3,000 PSI @ 400° F
316 SS	6,000 PSI @ 200° F Max.	10,000 PSI @ 200° F 3,000 PSI @ 400° F

See Page 5: Chart B Chart B

OPTION CODE	OPTION DESCRIPTION
AU7	½" Integral Tube Fitting - Parker® A-LOK Dual Ferrules (Process Ports)
AV7	½" Integral Tube Fitting - Swagelok® Dual Ferrules (Process Ports)
GA	Anti-Tamper Bonnet (All Positions)
GC	Anti-Tamper Bonnet (Isolate Valves Only)
GE	Anti-Tamper Bonnet (Vent Valve Only)
GJ	Bonnet Lock-Out (All Positions - Lock Not Provided)
GK	Bonnet Lock-Out (Isolate Valve(s) Only - Lock Not Provided)
GM	Bonnet Lock-Out (Vent Valve(s) Only - Lock Not Provided)
MH	Viton® O-Ring Flange Seals
TH	Hydrostatic Testing
VC	CS Versa-Mount Bracket
VS	316 SS Versa-Mount Bracket
VCH	CS Heavy-Duty Versa-Mount Bracket
VSH	316 SS Heavy-Duty Versa-Mount Bracket
W	Safety Bonnet Lock Plate
WA	CS
WAW3	300 SS
WAW9	316 SS
WK	Paper Tag
W1	316 SS Tag (20 Characters ~ See page 61)
W3	300 SS Standard Length Flange Bolts (CS Standard)
W9	316 SS Standard Length Flange Bolts (CS Standard)
XL	Clean for Critical Service (Oxygen or Chlorine)

Three-Valve Miniature Manifolds

.136" ORIFICE

Description

1/4" FNPT x 1/4" FNPT

Body Style

M-506 Hard Seat

M-506 Soft Seat

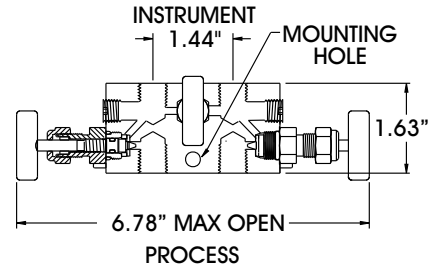
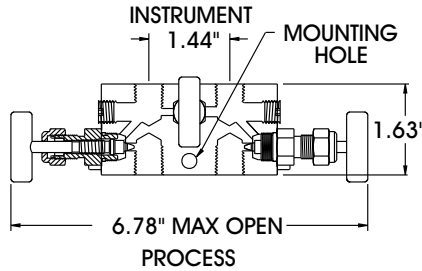
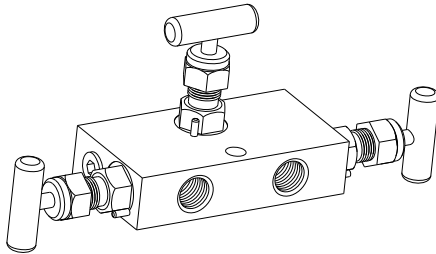

SEAT	MAX Cv RATINGS
Integral Metal	.25
Soft Washer	.22
Approx. Manifold Weight: 1.8 lbs each [M-506]	

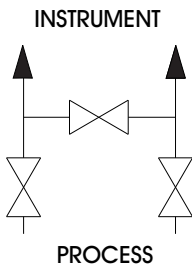

MATERIALS OF CONSTRUCTION

PART DESCRIPTION	CARBON STEEL	316 SS	MONEL®	HASTELLOY-C®
Body	ASTM A108-1215	ASTM A479-316	Manifold not available in Monel®.	Manifold not available in Hastelloy-C®.
Bonnet	ASTM A108-1215	ASTM A479-316		
Stem	ASTM A582-303	ASTM A479-316		
Seal Retainer	ASTM A479-316	ASTM A479-316		
Handle Assembly	ASTM A108	ASTM A582 (18-8)		
Plug(s)	ASTM A108	ASTM A182-F (18-8)		

- Carbon Steel Manifolds are Zinc Cobalt Plated with Dichromate Dip
- 316 SS Manifolds Meet NACE MR0175 Requirements (Latest Revision)
- 100% Pressure Tested

Three-Valve Miniature Manifolds

.136" ORIFICE

THREE-VALVE MINIATURE MANIFOLDS

ORDERING INFORMATION

BODY STYLE	BODY CODE	SEAT CODE	STEM SEAL CODE	OPTION CODES
Hard Seat				
M - 5 0 6			-	
Soft Seat				
M - 5 0 6			-	

BODY CODE	
[Std.] Carbon Steel	C
[Std.] 316 SS	S

HARD SEAT CODE	
[Std.] Integral Metal	M

SOFT SEAT CODE	
D	Delrin® Washer [Std.]
K	Kel-F® Washer
P	Peek® Washer
T	Teflon® Washer
Z	Tefzel Washer

STEM SEAL CODE	
[Std.] Teflon® Packed	T
Grafoil® Packed	G
Viton® O-Ring	V

OPTION CODE	OPTION DESCRIPTION
H5	CS Mini Round Handle
H6	SS Mini Round Handle
WK	Paper Tag
W1	316 SS Tag (20 Characters ~ See page 61)
XL	Clean for Critical Service (Oxygen or Chlorine)

PRESSURE & TEMPERATURE

BODY MATERIAL	METAL SEAT	METAL SEAT
	Teflon Packed or Viton O-ring	Grafoil Packed
Carbon Steel	6,000 PSI @ 200° F Max.	2,000 PSI @ 450° F Max.
316 SS	6,000 PSI @ 200° F Max.	2,000 PSI @ 450° F Max.
See Page 5:	Chart F	Chart F
BODY MATERIAL	SOFT SEAT (Delrin)	SOFT SEAT (Peek)
	Teflon Packed or Viton O-ring	Teflon Packed or Viton O-ring
Carbon Steel	3,000 PSI @ 200° F Max.	6,000 PSI @ 200° F 3,000 PSI @ 400° F
316 SS	3,000 PSI @ 200° F Max.	6,000 PSI @ 200° F 3,000 PSI @ 400° F
See Page 5:	Chart C	Chart C

Three-Valve Fugitive Emissions Manifold

.187" ORIFICE

Description

1/2" FNPT x Flange

Body Style

M-694 Hard Seat

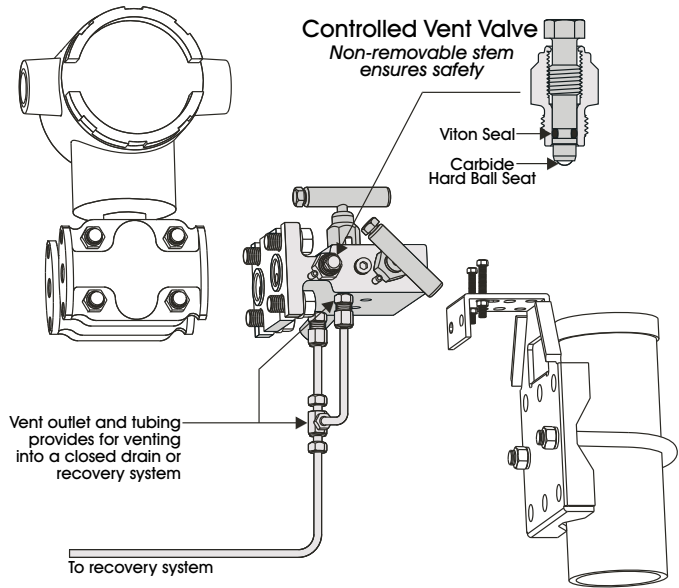
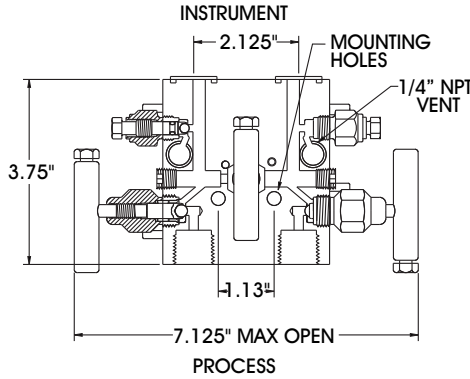
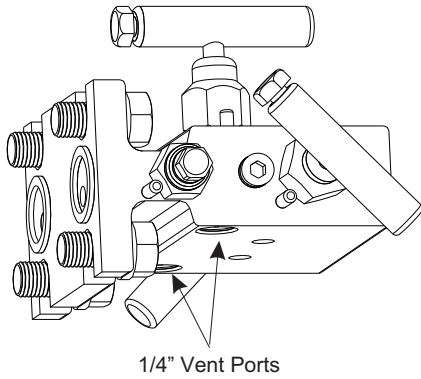

MATERIALS OF CONSTRUCTION

SEAT	MAX Cv RATINGS
Hard Ball / Cone	.53
Approx. Manifold Weight: 5.2 lbs each [M-694]	

PART DESCRIPTION	CARBON STEEL	A105 CARBON STEEL	316 SS	MONEL®	HASTELLOY-C®
Body	ASTM A108-1215	ASTM A105-CF	ASTM A479-316	ASTM B164-N04400	ASTM B575-N10276 or ASTM A494 CW-12MW
Bonnet	ASTM A108-1215	ASTM A479-316	ASTM A479-316	ASTM B164-N04405	ASTM B574-N10276
Stem	ASTM A582-303	ASTM A479-316	ASTM A479-316	ASTM B164-N04405	ASTM B574-N10276
Seal Retainer	ASTM A479-316	ASTM A479-316	ASTM A479-316	ASTM B164-N04405	ASTM B574-N10276
Handle Assembly	ASTM A108	ASTM A108	ASTM A582 (18-8)	ASTM A582 (18-8)	ASTM A582 (18-8)
Plug(s)	ASTM A108	ASTM F593 (18.8)	ASTM A182-F (18-8)	ASTM B164-N04405	ASTM B574-N10276
Mounting Bolts	ASTM A449-TYPE 1	ASTM A449-TYPE 1	ASTM A449-TYPE 1	ASTM F593 (18-8)	ASTM F593 (18-8)

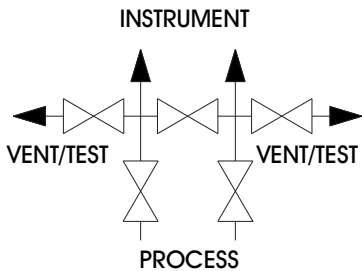

- Carbon Steel Manifolds are Zinc Cobalt Plated with Dichromate Dip
- 316 SS Manifolds Meet NACE MR0175 Requirements (Latest Revision)
- 100% Pressure Tested
- Carbon Steel Weld End Connection Bodies are AISI 1018

Three-Valve Fugitive Emissions Manifolds

.187" ORIFICE

THREE-VALVE FUGITIVE EMISSIONS

ORDERING INFORMATION

BODY STYLE	BODY CODE	SEAT CODE	STEM SEAL CODE	OPTION CODES
Hard Seat				
M - 6 9 4			-	

BODY CODE	
[Std.] Carbon Steel	C
A105 Carbon Steel	P
[Std.] 316 SS	S
Monel®	M
Hastelloy-C®	H

HARD SEAT CODE	
C	Carbide Ball [Std.]
R	Ceramic Ball
6	316 SS Ball
H	Hastelloy-C®
N	K-Monel®

STEM SEAL CODE		
Block Valve(s)	Vent Valve(s)	
[Std.] Teflon® Pressure-Core™	Viton® O-Ring [Std.]	T
Grafoil® Packed	Grafoil® Packed	G
Viton® O-Ring	Viton® O-Ring	V
Teflon® Packed	Teflon® Packed	P
Low-Temp Pressure-Core™	Fluorosilicone O-Ring	J

OPTIONS

- **Steam Trace Block**
- Versa-Mount Brackets
- Bonnet Handle Lock-Out
- Bonnet Lock Plates
- Integral Tube Fitting Connections

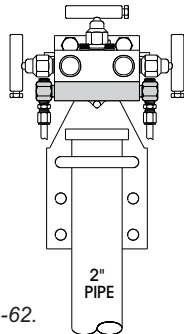

See Options/Accessories Pages 61-62.

PRESSURE & TEMPERATURE

BODY MATERIAL	HARD SEAT	
	Teflon Pressure-Core	Grafoil
Carbon Steel Code C	10,000 PSI @ 200° F 8,000 PSI @ 450° F	Not Available.
A105 Carbon Steel Code P	10,000 PSI @ 200° F 8,000 PSI @ 450° F	6,000 PSI @ 200° F 1,500 PSI @ 800° F
316 SS Code S	10,000 PSI @ 200° F 8,000 PSI @ 450° F	6,000 PSI @ 200° F 1,500 PSI @ 1,000° F
See Page 5: Chart D Chart F		

OPTION CODE	OPTION DESCRIPTION
AU7	½" Integral Tube Fitting - Parker® A-LOK Dual Ferrules (Process Ports)
AV7	½" Integral Tube Fitting - Swagelok® Dual Ferrules (Process Ports)
CVSCF	Vent Valve Seal Material: Fluorosilicone O-Ring
GC	Anti-Tamper Bonnet (Isolate Valves Only)
GD	Anti-Tamper Bonnet (Equalizer Valve Only)
GK	Bonnet Lock-Out (Isolate Valves Only - Lock Not Provided)
GL	Bonnet Lock-Out (Equalizer Valve Only - Lock Not Provided)
MH	Viton® O-Ring Flange Seals
MU	Dielectric Isolation (Flange Manifolds Only)
TC	Steam Trace Block - Carbon Steel
TH	Hydrostatic Testing
TS	Steam Trace Block - 316 SS
VC	CS Versa-Mount Bracket
VS	316 SS Versa-Mount Bracket
VCH	CS Heavy-Duty Versa-Mount Bracket
VSH	316 SS Heavy-Duty Versa-Mount Bracket
W	Safety Bonnet Lock Plate
WA	CS
WAW3	300 SS
WAW9	316 SS
WK	Paper Tag
W1	316 SS Tag (20 Characters ~ See page 61)
W3	300 SS Standard Length Flange Bolts (CS Standard)
W9	316 SS Standard Length Flange Bolts (CS Standard)
XL	Clean for Critical Service (Oxygen or Chlorine)

Three-Valve Manifolds

.187" ORIFICE

Description

1/2" FNPT x 1/2" FNPT

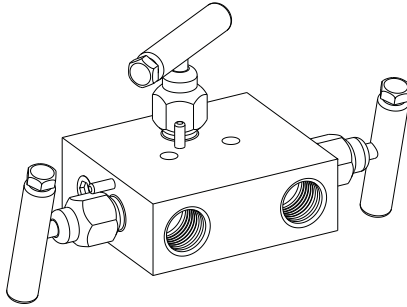

Body Style

M-500 Hard Seat

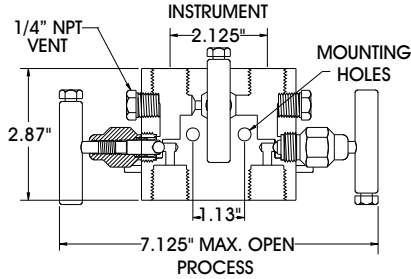

M-501 Soft Seat

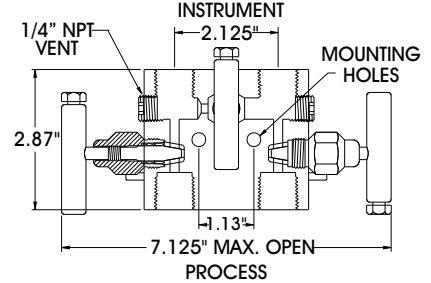

1/2" FNPT x Flange

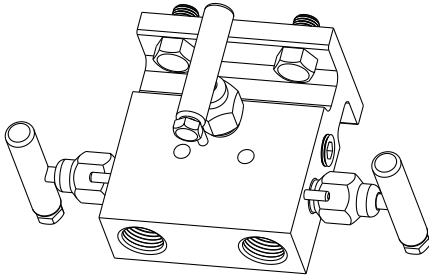

M-650 Hard Seat

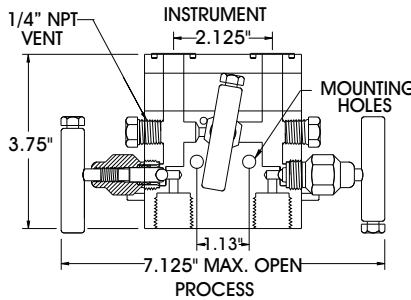

M-651 Soft Seat

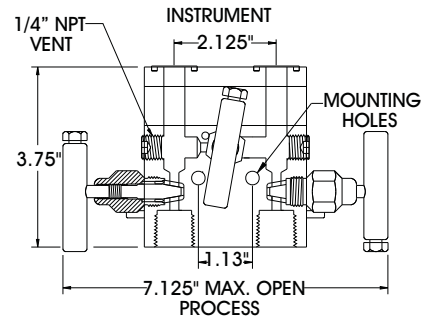

Flange x Flange

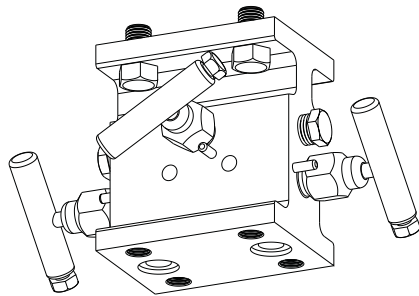

M-750 Hard Seat

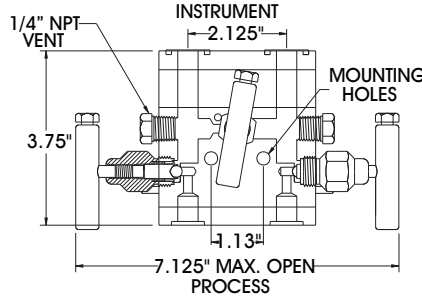

M-751 Soft Seat

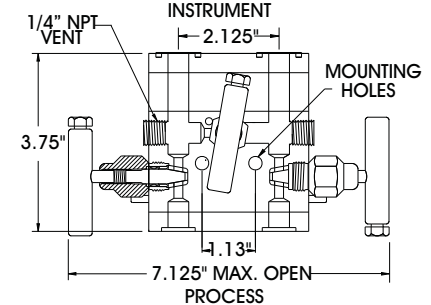

MATERIALS OF CONSTRUCTION

SEAT	MAX Cv RATINGS
Hard Ball	.53
Soft Cone	.83
Approx. Manifold Weight:	4.2 lbs each [M-500 / 501]
	5.2 lbs each [M-650 / 651]
	5.7 lbs each [M-750 / 751]

PART DESCRIPTION	CARBON STEEL	A105 CARBON STEEL	316 SS	MONEL®	HASTELLOY-C®
Body	ASTM A108-1215	ASTM A105 CF	ASTM A479-316	ASTM B164-N04405 or ASTM B164-N04400	ASTM B575-N10276 or ASTM A494 CW-12MW
Bonnet	ASTM A108-1215	ASTM A479-316	ASTM A479-316	ASTM B165-N04405	ASTM B574-N10276
Stem	ASTM A582-303	ASTM A479-316	ASTM A479-316	ASTM B164-N04405	ASTM B574-N10276
Seal Retainer	ASTM A479-316	ASTM A479-316	ASTM A479-316	ASTM B164-N04405	ASTM B574-N10276
Handle Assembly	ASTM A108	ASTM A108	ASTM A582 (18-8)	ASTM A582 (18-8)	ASTM A582 (18-8)
Plug(s)	ASTM A108	ASTM F593 (18.8)	ASTM A182-F (18-8)	ASTM B164-N04405	ASTM B574-N10276
Mounting Bolts	ASTM A449-TYPE 1	ASTM A449-TYPE 1	ASTM A449-TYPE 1	ASTM F593 (18-8)	ASTM F593 (18-8)

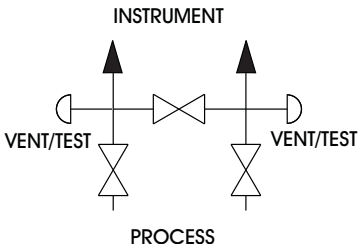

- Carbon Steel Manifolds are Zinc Cobalt Plated with Dichromate Dip
- 316 SS Manifolds Meet NACE MR0175 Requirements (Latest Revision)
- 100% Pressure Tested
- Carbon Steel Weld End Connection Bodies are AISI 1018

Three-Valve Manifolds

.187" ORIFICE

THREE-VALVE MANIFOLDS

ORDERING INFORMATION

BODY STYLE	BODY CODE	SEAT CODE	STEM SEAL CODE	OPTION CODES
Hard Seat				
M - 500			-	
M - 650			-	
M - 750			-	
Soft Seat				
M - 501			-	
M - 651			-	
M - 751			-	

BODY CODE	
[Std.] Carbon Steel	C
A105 Carbon Steel	P
[Std.] 316 SS	S
Monel®	M
Hastelloy-C®	H

HARD SEAT CODE		SOFT SEAT CODE	
[Std.] Carbide Ball	C	D	Delrin® Cone [Std.]
Ceramic Ball	R	K	Kel-F® Cone
316 SS Ball	6	P	PEEK® Cone
K-Monel® Ball	N	T	Teflon® Cone
Hastelloy-C® Ball	H	Z	Tefzel Cone

STEM SEAL CODE	
[Std.] Teflon® Pressure-Core™	T
Teflon® Pressure-Core™ Back-up	K
Grafoil® Packed	G
Viton® O-Ring	V
Low-Temp Pressure-Core™	J
Teflon® Packed [Hard Seat Only]	P

OPTIONS

- **Versa-Mount Brackets**
- Bonnet Handle Lock-Out
- Bonnet Lock Plates
- Steam Trace Block
- Integral Tube Fitting Connections

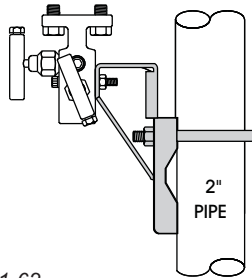

See Options/Accessories Pages 61-62.

OPTION CODE	OPTION DESCRIPTION
AU7	1/2" Integral Tube Fitting - Parker® A-LOK Dual Ferrules (Process Ports)
AV7	1/2" Integral Tube Fitting - Swagelok® Dual Ferrules (Process Ports)
GA	Anti-Tamper Bonnet (All Positions)
GC	Anti-Tamper Bonnet (Isolate Valve(s) Only)
GD	Anti-Tamper Bonnet (Equalizer Valve(s) Only)
GJ	Bonnet Lock-Out (All Positions - Lock Not Provided)
GK	Bonnet Lock-Out (Isolate Valve(s) Only - Lock Not Provided)
GL	Bonnet Lock-Out (Equalizer Valve(s) Only - Lock Not Provided)
ME	Slotted Instrument Flange Using Bolts over 3"
MH	Viton® O-Ring Flange Seals
MU	Dielectric Isolation (Flange Manifolds Only)
M7	Required Slotting for Rosemount® 1151 Transmitters Series 6 & Above (Flange Manifolds Only)
PB	(2) 1/4" Constant Purge Ports (Bottom) See pg. 61 for port locations.
PT	(2) 1/4" Constant Purge Ports (Top) See pg. 61 for port locations.
P1	Purge or Test Connections
TC	Steam Trace Block - Carbon Steel
TH	Hydrostatic Testing
TS	Steam Trace Block - 316 SS
VA	Bracket Spacer for Flange to Flange Manifolds
VC	CS Versa-Mount Bracket
VS	316 SS Versa-Mount Bracket
VCH	CS Heavy-Duty Versa-Mount Bracket
VSH	316 SS Heavy-Duty Versa-Mount Bracket
W	Safety Bonnet Lock Plate
WA	CS
WAW3	300 SS 2-1/4" Bolts for Rosemount® 3051C, 3095, or 2024 with Coplanar™ (Flange Manifolds Only)
WAW9	316 SS
WK	Paper Tag
W1	316 SS Tag (20 Characters ~ See page 61)
W3	300 SS Standard Length Flange Bolts (CS Standard)
W9	316 SS Standard Length Flange Bolts (CS Standard)
XL	Clean for Critical Service (Oxygen or Chlorine)
X3	(2) 1/4" Test Ports on Instrument Flange (Flange Manifolds Only) See pg. 61 for port locations.

PRESSURE & TEMPERATURE

BODY MATERIAL	HARD SEAT Teflon Pressure-Core CODE T	HARD SEAT Teflon Pressure-Core CODE K	HARD SEAT Grafoil
	Carbon Steel Code C	10,000 PSI @ 200° F 8,000 PSI @ 450° F	6,000 PSI @ 400° F
A105 Carbon Steel Code P	10,000 PSI @ 200° F 8,000 PSI @ 450° F	Not Available	6,000 PSI @ 200° F 1,500 PSI @ 800° F
316 SS Code S	10,000 PSI @ 200° F 8,000 PSI @ 450° F	6,000 PSI @ 400° F	6,000 PSI @ 200° F 1,500 PSI @ 1,000° F
See Page 5: Chart D Chart D Chart F			
BODY MATERIAL	SOFT SEAT (Delrin) Teflon Pressure-Core CODE T	SOFT SEAT (Peak) Teflon Pressure-Core CODE T	
	Carbon Steel Code C	6,000 PSI @ 200° F	10,000 PSI @ 200° F 3,000 PSI @ 400° F
316 SS Code S	6,000 PSI @ 200° F	10,000 PSI @ 200° F 3,000 PSI @ 400° F	
See Page 5: Chart A Chart B			

Three-Valve Manifolds

.250" ORIFICE

Description

1/2" FNPT x 1/2" FNPT

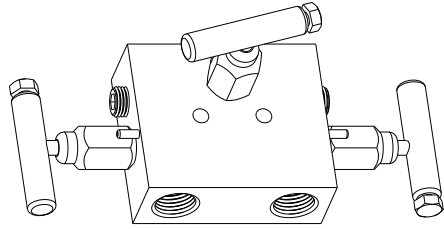

1/2" FNPT x Flange

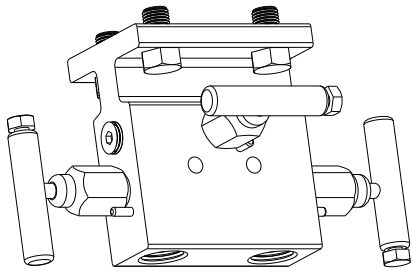

Flange x Flange

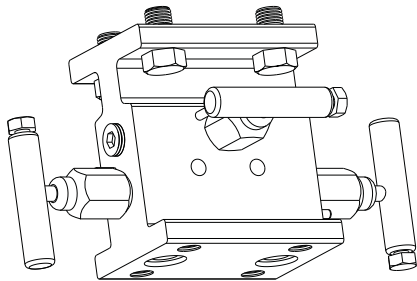

Body Style

M2-501 Soft Seat

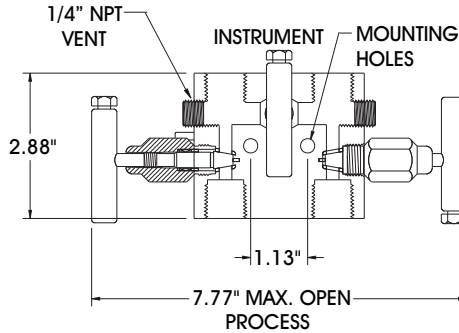

M2-651 Soft Seat

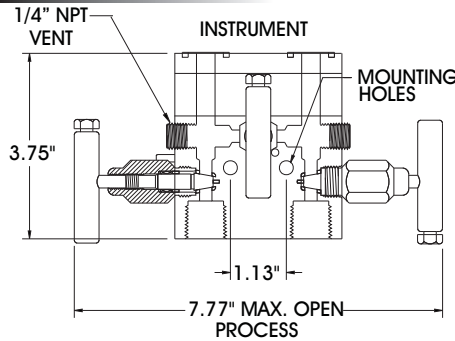

M2-751 Soft Seat

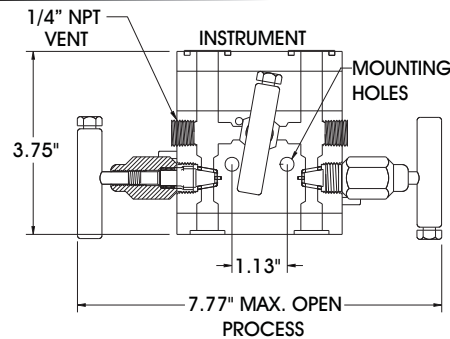

SEAT	MAX Cv RATINGS
Soft Cone	1.4
Approx. Manifold Weight:	4.2 lbs each [M2-501] 5.2 lbs each [M2-651] 5.7 lbs each [M2-751]

MATERIALS OF CONSTRUCTION

PART DESCRIPTION	CARBON STEEL	316 SS	MONEL®	HASTELLOY-C®
Body	ASTM A108-1215	ASTM A479-316	ASTM B164-N04405 or ASTM B164-N04400	ASTM B575-N10276 or ASTM A494 CW-12MW
Bonnet	ASTM A108-1215	ASTM A479-316	ASTM B165-N04405	ASTM B574-N10276
Stem	ASTM A582-303	ASTM A479-316	ASTM B164-N04405	ASTM B574-N10276
Seal Retainer	ASTM A479-316	ASTM A479-316	ASTM B164-N04405	ASTM B574-N10276
Handle Assembly	ASTM A108	ASTM A582 (18-8)	ASTM A582 (18-8)	ASTM A582 (18-8)
Plug(s)	ASTM A108	ASTM A182-F (18-8)	ASTM B164-N04405	ASTM B574-N10276
Mounting Bolts	ASTM A449-TYPE 1	ASTM A449-TYPE 1	ASTM F593 (18-8)	ASTM F593 (18-8)

- Carbon Steel Manifolds are Zinc Cobalt Plated with Dichromate Dip
- 316 SS Manifolds Meet NACE MR0175 Requirements (Latest Revision)
- 100% Pressure Tested
- Carbon Steel Weld End Connection Bodies are AISI 1018

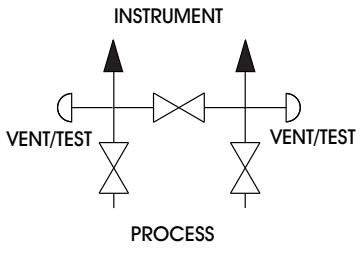

Three-Valve Manifolds

.250" ORIFICE

THREE-VALVE MANIFOLDS

ORDERING INFORMATION

BODY STYLE	BODY CODE	SEAT CODE	STEM SEAL CODE	OPTION CODES
Soft Seat				
M 2 - 5 0 1			-	
M 2 - 6 5 1			-	
M 2 - 7 5 1			-	

BODY CODE	
[Std.] Carbon Steel	C
[Std.] 316 SS	S
Monel®	M
Hastelloy-C®	H

SOFT SEAT CODE	
D	Delrin® Cone [Std.]
K	Kel-F® Cone
P	PEEK® Cone
T	Teflon® Cone
Z	Tefzel Cone

STEM SEAL CODE	
[Std.] Teflon® Pressure-Core™	T
Viton® O-Ring	V
Low-Temp Pressure-Core™	J

OPTIONS

- **Bonnet Lock Plates**
- Versa-Mount Brackets
- Bonnet Handle Lock-Out
- Steam Trace Block
- Integral Tube Fitting

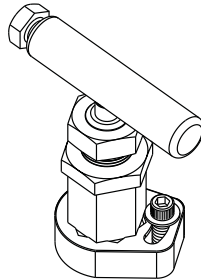

See Options/Accessories Pages 61-62.

PRESSURE & TEMPERATURE

BODY MATERIAL	SOFT SEAT (Delrin)	SOFT SEAT (Peek)
	Teflon Pressure-Core	Teflon Pressure-Core
Carbon Steel	6,000 PSI @ 200° F Max.	10,000 PSI @ 200° F 3,000 PSI @ 400° F
316 SS	6,000 PSI @ 200° F Max.	10,000 PSI @ 200° F 3,000 PSI @ 400° F
See Page 5:	Chart B	Chart B

OPTION CODE	OPTION DESCRIPTION
AU7	1/2" Integral Tube Fitting - Parker® A-LOK Dual Ferrules (Process Ports)
AV7	1/2" Integral Tube Fitting - Swagelok® Dual Ferrules (Process Ports)
GA	Anti-Tamper Bonnet (All Positions)
GC	Anti-Tamper Bonnet (Isolate Valve(S) Only)
GD	Anti-Tamper Bonnet (Equalizer Valve(s) Only)
GJ	Bonnet Lock-Out (All Positions - Lock Not Provided)
GK	Bonnet Lock-Out (Isolate Valve(s) Only - Lock Not Provided)
GL	Bonnet Lock-Out (Equalizer Valve(s) Only - Lock Not Provided)
ME	Slotted Instrument Flange Using Bolts over 3"
MH	Viton® O-Ring Flange Seals
MU	Dielectric Isolation (Flange Manifolds Only)
M7	Required Slotting for Rosemount® 1151 Transmitters Series 6 & Above (Flange Manifolds Only)
PB	(2) 1/4" Constant Purge Ports (Bottom) See pg. 61 for port locations.
PT	(2) 1/4" Constant Purge Ports (Top) See pg. 61 for port locations.
P1	Purge or Test Connections
TC	Steam Trace Block - Carbon Steel
TH	Hydrostatic Testing
TS	Steam Trace Block - 316 SS
VA	Bracket Spacer for Flange to Flange Manifolds
VC	CS Versa-Mount Bracket
VS	316 SS Versa-Mount Bracket
VCH	CS Heavy-Duty Versa-Mount Bracket
VSH	316 SS Heavy-Duty Versa-Mount Bracket
W	Safety Bonnet Lock Plate
WA	CS
WAW3	300 SS
WAW9	316 SS
WV	2-1/4" Bolts for Rosemount® 3051C, 3095, or 2024 with Coplanar™ (Flange Manifolds Only)
WK	Paper Tag
W1	316 SS Tag (20 Characters ~ See page 61)
W3	300 SS Standard Length Flange Bolts (CS Standard)
W9	316 SS Standard Length Flange Bolts (CS Standard)
XL	Clean for Critical Service (Oxygen or Chlorine)
X3	(2) 1/4" Test Ports on Instrument Flange (Flange Manifolds Only) See pg. 61 for port locations.

Three-Valve Manifolds

.375" ORIFICE

Description

1/2" FNPT x 1/2" FNPT

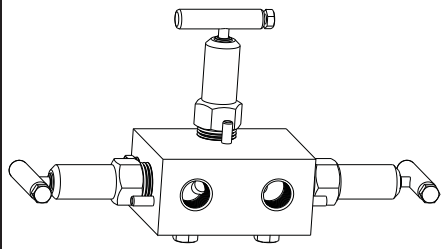

Body Style

M3-500 Hard Seat

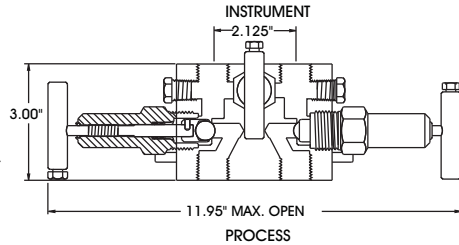

M3-551 Soft Seat

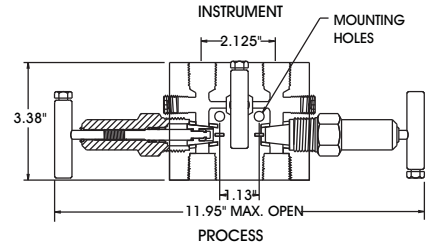

1/2" FNPT x Flange

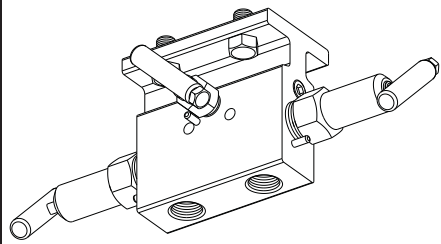

M3-650 Hard Seat

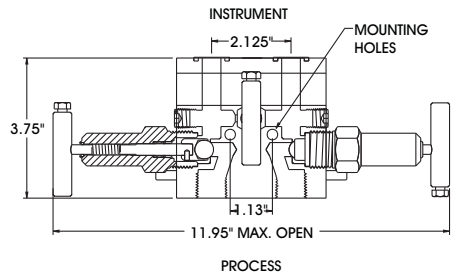

M3-651 Soft Seat

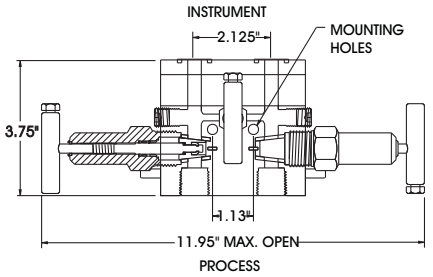

Flange x Flange

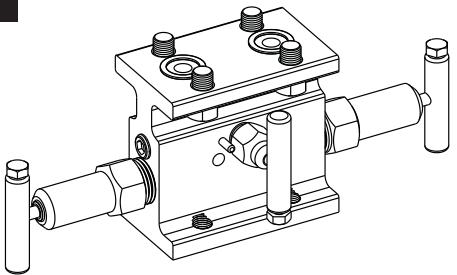

M3-750 Hard Seat

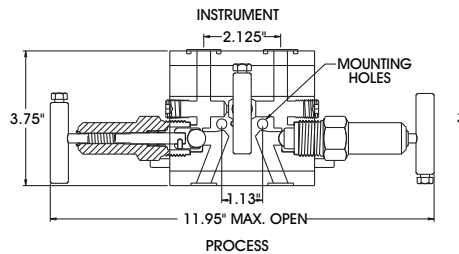

M3-751 Soft Seat

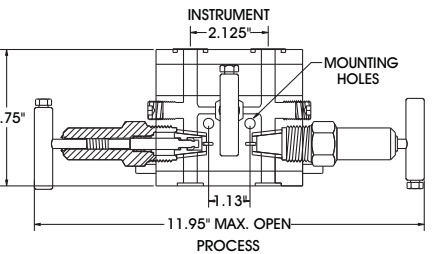

MATERIALS OF CONSTRUCTION

SEAT	MAX Cv RATINGS
Hard Ball	2.4
Hard Cone	3.0
Soft Cone	3.0

Approx. Manifold Weight:
 9.0 lbs each [M3-500]
 6.5 lbs each [M3-551]
 7.0 lbs each [M3-650 / 651]
 7.6 lbs each [M3-750 / 751]

PART DESCRIPTION	CARBON STEEL	A105 CARBON STEEL	316 SS	MONEL®	HASTELLOY-C®
Body	ASTM A108-1215	ASTM A105 CF	ASTM A479-316	ASTM B164-N04405 or ASTM B164-N04400	ASTM B575-N10276 or ASTM A494 CW-12MW
Bonnet	ASTM A108-1215	ASTM A479-316	ASTM A479-316	ASTM B165-N04405	ASTM B574-N10276
Stem	ASTM A582-303	ASTM A479-316	ASTM A479-316	ASTM B164-N04405	ASTM B574-N10276
Seal Retainer	ASTM A479-316	ASTM A479-316	ASTM A479-316	ASTM B164-N04405	ASTM B574-N10276
Handle Assembly	ASTM A108	ASTM A108	ASTM A582 (18-8)	ASTM A582 (18-8)	ASTM A582 (18-8)
Plug(s)	ASTM A108	ASTM F593 (18-8)	ASTM A182-F (18-8)	ASTM B164-N04405	ASTM B574-N10276
Mounting Bolts	ASTM A449-TYPE 1	ASTM A449-TYPE 1	ASTM A449-TYPE 1	ASTM F593 (18-8)	ASTM F593 (18-8)

- Carbon Steel Manifolds are Zinc Cobalt Plated with Dichromate Dip
- 316 SS Manifolds Meet NACE MR0175 Requirements (Latest Revision)
- 100% Pressure Tested
- Carbon Steel Weld End Connection Bodies are AISI 1018

M3-500 **M3-551/650/651/750/751**

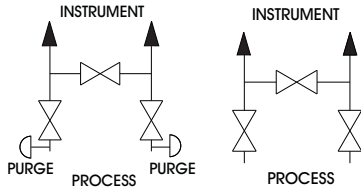

Three-Valve Manifolds

.375" ORIFICE

THREE-VALVE MANIFOLDS

ORDERING INFORMATION

BODY STYLE	BODY CODE	SEAT CODE	STEM SEAL CODE	OPTION CODES
Hard Seat				
M 3 - 5 0 0			-	
M 3 - 6 5 0			-	
M 3 - 7 5 0			-	
Soft Seat				
M 3 - 5 5 1			-	
M 3 - 6 5 1			-	
M 3 - 7 5 1			-	

BODY CODE	
[Std.] Carbon Steel	C
A105 Carbon Steel	P
[Std.] 316 SS	S
Monel®	M
Hastelloy-C®	H

HARD SEAT CODE	
[Std.] Carbide Ball	C
Ceramic Ball	R
316 SS Ball	6
K-Monel® Ball	N
Hastelloy-C® Ball	H

SOFT SEAT CODE	
Rylon® Cone [Std.]	L
Delrin® Cone	D
Kel-F® Cone	K
PEEK® Cone	P
Teflon® Cone	T
316 SS Cone	6

STEM SEAL CODE	
[Std.] Teflon® Pressure-Core™	T
Grafoil® Packed	G
Viton® O-Ring	V
Low-Temp Pressure-Core™	J
Teflon® Packed	P

OPTIONS

- **Integral Tube Fitting Connections**
- Versa-Mount Brackets
- Bonnet Handle Lock-Out
- Bonnet Lock Plates
- Steam Trace Block

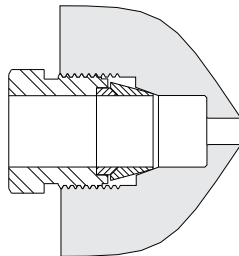

See Options/Accessories Pages 61-62.

OPTION CODE	OPTION DESCRIPTION
AU7	1/2" Integral Tube Fitting - Parker® A-LOK Dual Ferrules (Process Ports)
AV7	1/2" Integral Tube Fitting - Swagelok® Dual Ferrules (Process Ports)
GA	Anti-Tamper Bonnet (All Positions)
GC	Anti-Tamper Bonnet (Isolate Valves Only)
GD	Anti-Tamper Bonnet (Equalizer Valve(s) Only)
GJ	Bonnet Lock-Out (All Positions - Lock Not Provided)
GK	Bonnet Lock-Out (Isolate Valve(s) Only - Lock Not Provided)
GL	Bonnet Lock-Out (Equalizer Valve(s) Only - Lock Not Provided)
MA	Versa-Mount Bracket Holes (M3-500 Only)
ME	Slotted Instrument Flange Using Bolts over 3"
MH	Viton® O-Ring Flange Seals
MU	Dielectric Isolation (Flange Manifolds Only)
M7	Required Slotting for Rosemount® 1151 Transmitters Series 6 & Above (Flange Manifolds Only)
PB	(2) 1/4" Constant Purge Ports (Bottom) See pg. 61 for port locations.
PT	(2) 1/4" Constant Purge Ports (Top) See pg. 61 for port locations.
P1	Purge or Test Connections
TC	Steam Trace Block - Carbon Steel
TH	Hydrostatic Testing
TS	Steam Trace Block - 316 SS
VA	Bracket Spacer for Flange to Flange Manifolds
VC	CS Versa-Mount Bracket
VS	316 SS Versa-Mount Bracket
VCH	CS Heavy-Duty Versa-Mount Bracket
VSH	316 SS Heavy-Duty Versa-Mount Bracket
W	Safety Bonnet Lock Plate
WA	CS
WAW3	300 SS 2-1/4" Bolts for Rosemount® 3051C, 3095, or 2024 with Coplanar™ (Flange Manifolds Only)
WAW9	316 SS
WK	Paper Tag
W1	316 SS Tag (20 Characters ~ See page 61)
W3	300 SS Standard Length Flange Bolts (CS Standard)
W9	316 SS Standard Length Flange Bolts (CS Standard)
XL	Clean for Critical Service (Oxygen or Chlorine)
X3	(2) 1/4" Test Ports on Instrument Flange (Flange Manifolds Only) See pg. 61 for port locations.

PRESSURE & TEMPERATURE

BODY MATERIAL	HARD SEAT	
	Teflon Pressure-Core	Grafoil
Carbon Steel Code C	10,000 PSI @ 200° F 8,000 PSI @ 450° F	Not Available.
A105 Carbon Steel Code P	10,000 PSI @ 200° F 8,000 PSI @ 450° F	6,000 PSI @ 200° F 1,500 PSI @ 800° F
316 SS Code S	10,000 PSI @ 200° F 8,000 PSI @ 450° F	6,000 PSI @ 200° F 1,500 PSI @ 1,000° F
See Page 5: Chart D		Chart F
BODY MATERIAL	SOFT SEAT	
	SOFT SEAT (Delrin)	SOFT SEAT (Rylon)
Carbon Steel Code C	6,000 PSI @ 200° F Max.	1,500 PSI @ 200° F Max.
316 SS Code S	6,000 PSI @ 200° F Max.	1,500 PSI @ 200° F Max.
See Page 5: Chart E		Chart E

Five-Valve Manifolds

.187" ORIFICE

Description

1/2" FNPT x 1/2" FNPT

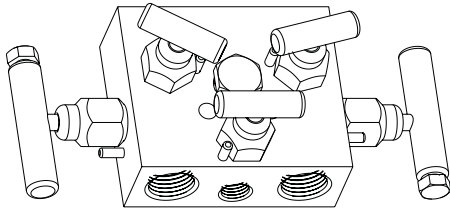

1/2" FNPT x Flange

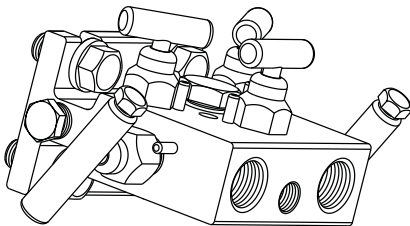

Flange x Flange

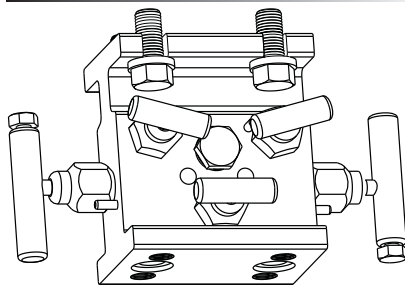

Body Style

M-502 Hard Seat

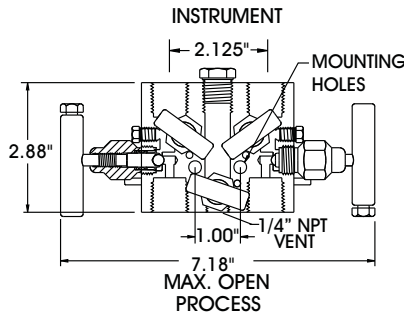

M-573 Soft Seat

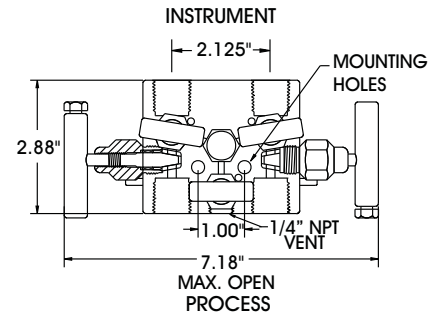

M-652 Hard Seat

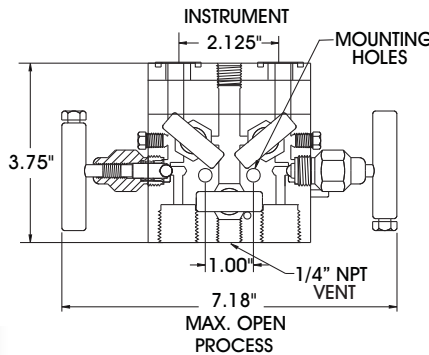

M-673 Soft Seat

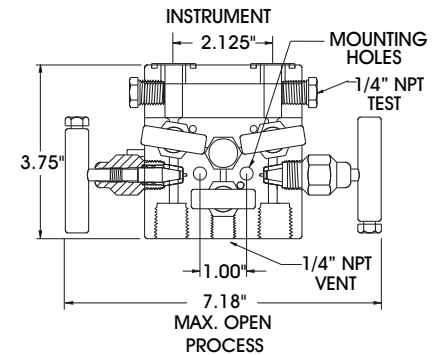

M-752 Hard Seat

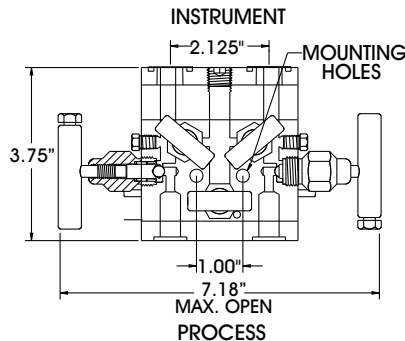

M-773 Soft Seat

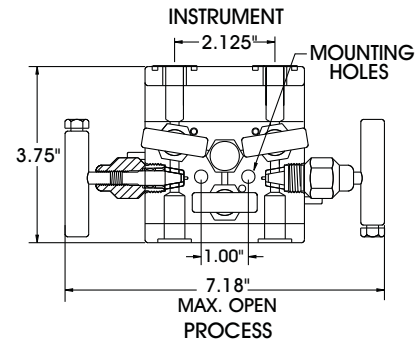

MATERIALS OF CONSTRUCTION

SEAT	MAX Cv RATINGS
Hard Ball / Cone	.53
Soft Cone	.83
Approx. Manifold Weight:	4.7 lbs each [M-502 / 573]
	5.7 lbs each [M-652 / 673]
	6.2 lbs each [M-752 / 773]

NOTE: M-502 / 573 / 652 / 752 / 773: TEST PORTS LOCATED ON BOTTOM SIDE OF MANIFOLD.

PART DESCRIPTION	CARBON STEEL	A105 CARBON STEEL	316 SS	MONEL®	HASTELLOY-C®
Body	ASTM A108-1215	ASTM A105 CF	ASTM A479-316	ASTM B164-N04405 or ASTM B164-N04400	ASTM B575-N10276 or ASTM A494 CW-12MW
Bonnet	ASTM A108-1215	ASTM A479-316	ASTM A479-316	ASTM B164-N04405	ASTM B574-N10276
Stem	ASTM A582-303	ASTM A479-316	ASTM A479-316	ASTM B164-N04405	ASTM B574-N10276
Seal Retainer	ASTM A479-316	ASTM A479-316	ASTM A479-316	ASTM B164-N04405	ASTM B574-N10276
Handle Assembly	ASTM A108	ASTM A108	ASTM A582 (18-8)	ASTM A582 (18-8)	ASTM A582 (18-8)
Plug(s)	ASTM A108	ASTM F593 (18-8)	ASTM A182-F (18-8)	ASTM B164-N04405	ASTM B574-N10276
Mounting Bolts	ASTM A449-TYPE 1	ASTM A449-TYPE 1	ASTM A449-TYPE 1	ASTM F593 (18-8)	ASTM F593 (18-8)

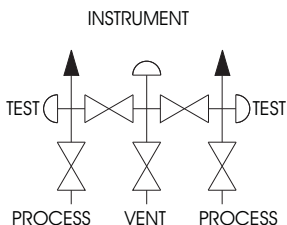

- Carbon Steel Manifolds are Zinc Cobalt Plated with Dichromate Dip
- 316 SS Manifolds Meet NACE MR0175 Requirements (Latest Revision)
- 100% Pressure Tested
- Carbon Steel Weld End Connection Bodies are AISI 1018

Five-Valve Manifolds

.187" ORIFICE

FIVE-VALVE MANIFOLDS

ORDERING INFORMATION

BODY STYLE	BODY CODE	SEAT CODE	STEM SEAL CODE	OPTION CODES
Hard Seat				
M - 502			-	
M - 652			-	
M - 752			-	
Soft Seat				
M - 573			-	
M - 673			-	
M - 773			-	

BODY CODE	
[Std.] Carbon Steel	C
A105 Carbon Steel	P
[Std.] 316 SS	S
Monel®	M
Hastelloy-C®	H

HARD SEAT CODE	
[Std.] Carbide Ball	C
Ceramic Ball	R
316 SS Ball	6
K-Monel®	N
Hastelloy-C®	H

SOFT SEAT CODE	
Delrin® Cone / Washer [Std.]	D
Kel-F® Cone / Washer	K
PEEK® Cone / Washer	P
Teflon® Cone / Washer	T
Tefzel Cone / Washer	Z

STEM SEAL CODE	
[Std.] Teflon® Pressure-Core™	T
Grafoil® Packed	G
Viton® O-Ring	V
Low-Temp Pressure-Core™	J
Teflon® Packed [Hard Seat Only]	P

OPTIONS

- **Steam Trace Block**
- Versa-Mount Brackets
- Bonnet Handle Lock-Out
- Bonnet Lock Plates
- Integral Tube Fitting Connections

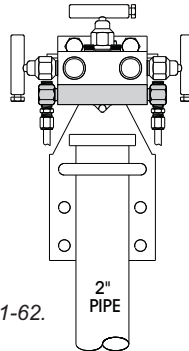

See Options/Accessories Pages 61-62.

OPTION CODE	OPTION DESCRIPTION
AU7	1/2" Integral Tube Fitting - Parker® A-LOK Dual Ferrules (Process Ports)
AV7	1/2" Integral Tube Fitting - Swagelok® Dual Ferrules (Process Ports)
GC	Anti-Tamper Bonnet (Isolate Valve(s) Only)
GK	Bonnet Lock-Out (Isolate Valve(s) Only - Lock Not Provided)
MH	Viton® O-Ring Flange Seals
MU	Dielectric Isolation (Flange Manifolds Only)
M7	Required Slotting for Rosemount® 1151 Transmitters Series 6 & Above (Flange Manifolds Only)
PB	(2) 1/4" Constant Purge Ports (Bottom) See pg. 61 for port locations.
PS	(2) 1/4" Side Purge with Plugs (M-773 and M-752 Only) See pg. 61 for port locations.
TC	Steam Trace Block - Carbon Steel
TH	Hydrostatic Testing
TS	Steam Trace Block - 316 SS (Not available with M-773)
VC	CS Versa-Mount Bracket
VS	316 SS Versa-Mount Bracket
VCH	CS Heavy-Duty Versa-Mount Bracket
VSH	316 SS Heavy-Duty Versa-Mount Bracket
W	Safety Bonnet Lock Plate
WA	CS
WAW3	300 SS
WAW9	316 SS
WAW3	2-1/4" Bolts for Rosemount® 3051C, 3095, or 2024 with Coplanar™ (Flange Manifolds Only)
WK	Paper Tag
W1	316 SS Tag (20 Characters ~ See page 61)
W3	300 SS Standard Length Flange Bolts (CS Standard)
W9	316 SS Standard Length Flange Bolts (CS Standard)
XL	Clean for Critical Service (Oxygen or Chlorine)
X3	(2) 1/4" Test Ports on Instrument Flange (Available on M-652, M-752 and M-773) See pg. 61 for port locations.

PRESSURE & TEMPERATURE

BODY MATERIAL	HARD SEAT	HARD SEAT
	Teflon Pressure-Core	Grafoil
Carbon Steel Code C	10,000 PSI @ 200° F 8,000 PSI @ 450° F	Not Available.
A105 Carbon Steel Code P	10,000 PSI @ 200° F 8,000 PSI @ 450° F	6,000 PSI @ 200° F 1,500 PSI @ 800° F
316 SS Code S	10,000 PSI @ 200° F 8,000 PSI @ 450° F	6,000 PSI @ 200° F 1,500 PSI @ 1,000° F
See Page 5:	Chart D	Chart F
BODY MATERIAL	SOFT SEAT (Delrin)	SOFT SEAT (Peek)
	Teflon Pressure-Core	Teflon Pressure-Core
Carbon Steel Code C	6,000 PSI @ 200° F Max.	6,000 PSI @ 200° F 3,000 PSI @ 400° F
316 SS Code S	6,000 PSI @ 200° F Max.	6,000 PSI @ 200° F 3,000 PSI @ 400° F
See Page 5:	Chart A	Chart A

Five-Valve Manifolds

.250" ORIFICE

Description

1/2" FNPT x 1/2" FNPT

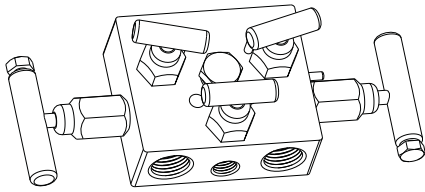

1/2" FNPT x Flange

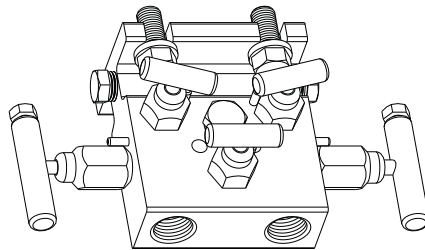

Flange x Flange

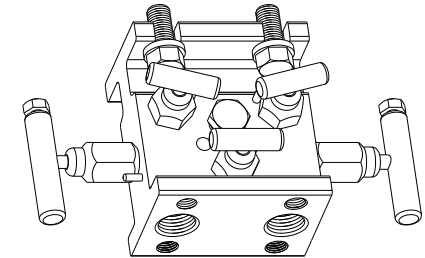

Body Style

M2-573 Soft Seat

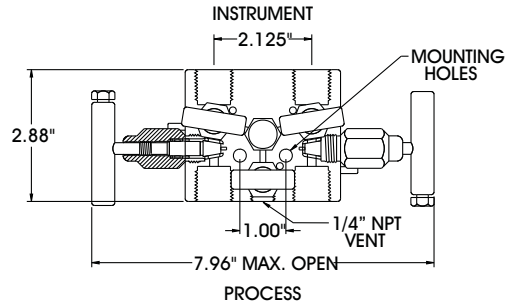

M2-673 Soft Seat

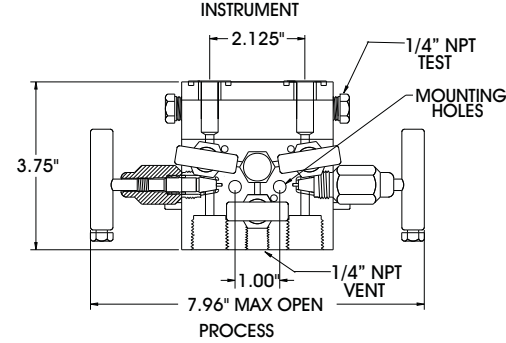

M2-773 Soft Seat

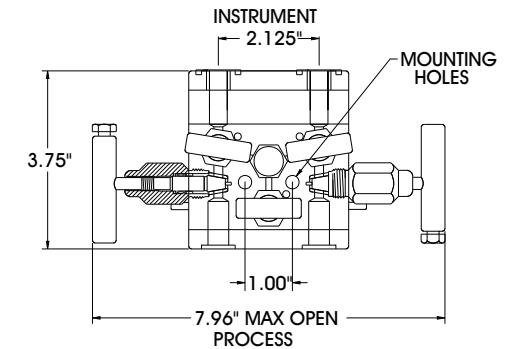

MATERIALS OF CONSTRUCTION

SEAT	MAX Cv RATINGS
Soft Cone	1.4
Approx. Manifold Weight:	4.7 lbs each [M2-573] 5.7 lbs each [M2-673] 6.2 lbs each [M2-773]

NOTE: M2-573 / 773: TEST PORTS LOCATED ON BOTTOM SIDE OF MANIFOLD.

PART DESCRIPTION	CARBON STEEL	316 SS	MONEL®	HASTELLOY-C®
Body	ASTM A108-1215	ASTM A479-316	ASTM B164-N04405 or ASTM B164-N04400	ASTM B575-N10276 or ASTM A494 CW-12MW
Bonnet	ASTM A108-1215	ASTM A479-316	ASTM B164-N04405	ASTM B574-N10276
Stem	ASTM A582-303	ASTM A479-316	ASTM B164-N04405	ASTM B574-N10276
Seal Retainer	ASTM A479-316	ASTM A479-316	ASTM B164-N04405	ASTM B574-N10276
Handle Assembly	ASTM A108	ASTM A582 (18-8)	ASTM A582 (18-8)	ASTM A582 (18-8)
Plug(s)	ASTM A108	ASTM A182-F (18-8)	ASTM B164-N04405	ASTM B574-N10276
Mounting Bolts	ASTM A449-TYPE 1	ASTM A449-TYPE 1	ASTM F593 (18-8)	ASTM F593 (18-8)

- Carbon Steel Manifolds are Zinc Cobalt Plated with Dichromate Dip
- 316 SS Manifolds Meet NACE MR0175 Requirements (Latest Revision)
- 100% Pressure Tested
- Carbon Steel Weld End Connection Bodies are AISI 1018

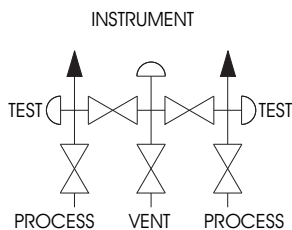

Five-Valve Manifolds

.250" ORIFICE

FIVE-VALVE MANIFOLDS

ORDERING INFORMATION

BODY STYLE	BODY CODE	SEAT CODE	STEM SEAL CODE	OPTION CODES
Soft Seat				
M 2 - 5 7 3			-	
M 2 - 6 7 3			-	
M 2 - 7 7 3			-	

BODY CODE	
[Std.] Carbon Steel	C
[Std.] 316 SS	S
Monel®	M
Hastelloy-C®	H

SOFT SEAT CODE	
D	Delrin® Cone [Std.]
K	Kel-F® Cone
P	PEEK® Cone
T	Teflon® Cone
Z	Tefzel Cone

STEM SEAL CODE	
[Std.] Teflon® Pressure-Core™	T
Viton® O-Ring	V
Low-Temp Pressure-Core™	J

OPTIONS

- **Versa-Mount Brackets**
- Bonnet Handle Lock-Out
- Bonnet Lock Plates
- Steam Trace Block
- Integral Tube Fitting Connections

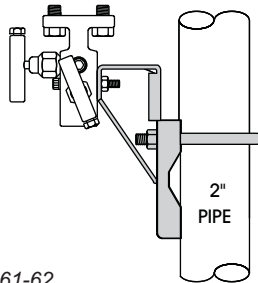

See Options/Accessories Pages 61-62.

PRESSURE & TEMPERATURE

BODY MATERIAL	SOFT SEAT (Delrin)	SOFT SEAT (Peek)
	Teflon Pressure-Core	Teflon Pressure-Core
Carbon Steel	6,000 PSI @ 200° F Max.	6,000 PSI @ 200° F 3,000 PSI @ 400° F
316 SS	6,000 PSI @ 200° F Max.	6,000 PSI @ 200° F 3,000 PSI @ 400° F
See Page 5:	Chart A	Chart A

OPTION CODE	OPTION DESCRIPTION
AU7	½" Integral Tube Fitting - Parker® A-LOK Dual Ferrules (Process Ports)
AV7	½" Integral Tube Fitting - Swagelok® Dual Ferrules (Process Ports)
GC	Anti-Tamper Bonnet (Isolate Valves Only)
GK	Bonnet Lock-Out (Isolate Valve(s) Only - Lock Not Provided)
MH	Viton® O-Ring Flange Seals
MU	Dielectric Isolation (Flange Manifolds Only)
M7	Required Slotting for Rosemount® 1151 Transmitters Series 6 & Above (Flange Manifolds Only)
PB	(2) ¼" Constant Purge Ports (Bottom) See pg. 61 for port locations.
PT	(2) ¼" Constant Purge Ports (Top - M2-673/773 Only) See pg. 61 for port locations.
P1	Purge or Test Connections
TC	Steam Trace Block - Carbon Steel
TH	Hydrostatic Testing
TS	Steam Trace Block - 316 SS
VC	CS Versa-Mount Bracket
VS	316 SS Versa-Mount Bracket
VCH	CS Heavy-Duty Versa-Mount Bracket
VSH	316 SS Heavy-Duty Versa-Mount Bracket
W	Safety Bonnet Lock Plate
WA	CS
WAW3	300 SS
WAW9	316 SS
W3	300 SS
W9	316 SS
XL	Clean for Critical Service (Oxygen or Chlorine)
X3	(2) ¼" Test Ports on Instrument Flange (Available on M2-773 Only) See pg. 61 for port locations.

Five-Valve Manifolds

.375" ORIFICE

Description

1/2" FNPT x 1/2" FNPT

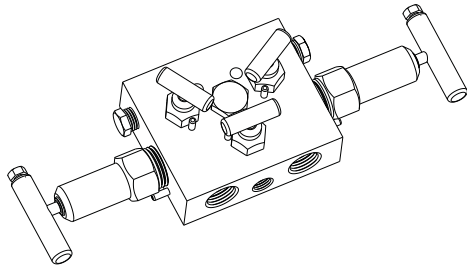

1/2" FNPT x Flange

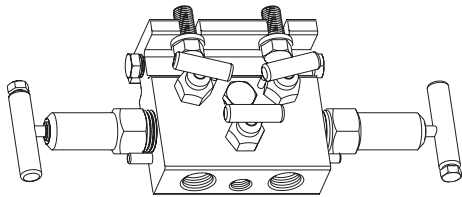

Flange x Flange

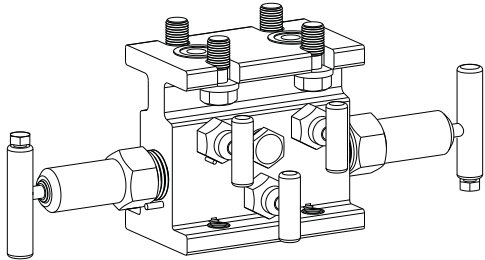

Body Style

M3-573 Soft Seat

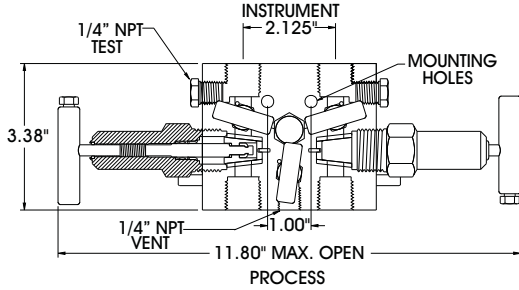

M3-673 Soft Seat

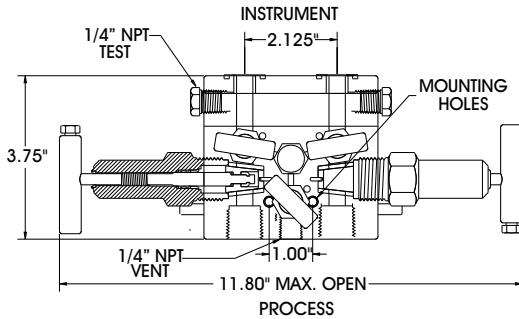

M3-773 Soft Seat

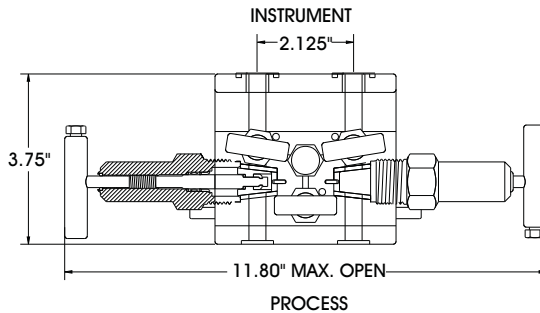

MATERIALS OF CONSTRUCTION

SEAT	MAX Cv RATINGS
Soft Cone	3.0
Approx. Manifold Weight:	7.1 lbs each [M3-573] 7.7 lbs each [M3-673] 8.3 lbs each [M3-773]

NOTE: M3-773: TEST PORTS LOCATED ON BOTTOM SIDE OF MANIFOLD.

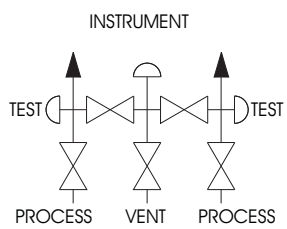

PART DESCRIPTION	CARBON STEEL	316 SS	MONEL®	HASTELLOY-C®
Body	ASTM A108-1215	ASTM A479-316	ASTM B164-N04405 or ASTM B164-N04400	ASTM B575-N10276 ASTM A494 CW-12MW
Bonnet	ASTM A108-1215	ASTM A479-316	ASTM B164-N04405	ASTM B574-N10276
Stem	ASTM A582-303	ASTM A479-316	ASTM B164-N04405	ASTM B574-N10276
Seal Retainer	ASTM A479-316	ASTM A479-316	ASTM B164-N04405	ASTM B574-N10276
Handle Assembly	ASTM A108	ASTM A582 (18-8)	ASTM A582 (18-8)	ASTM A582 (18-8)
Plug(s)	ASTM A108	ASTM A182-F (18-8)	ASTM B164-N04405	ASTM B574-N10276
Mounting Bolts	ASTM A449-TYPE 1	ASTM A449-TYPE 1	ASTM F593 (18-8)	ASTM F593 (18-8)

- Carbon Steel Manifolds are Zinc Cobalt Plated with Dichromate Dip
- 316 SS Manifolds Meet NACE MR0175 Requirements (Latest Revision)
- 100% Pressure Tested
- Carbon Steel Weld End Connection Bodies are AISI 1018

Five-Valve Manifolds

.375" ORIFICE

FIVE-VALVE MANIFOLDS

ORDERING INFORMATION

BODY STYLE	BODY CODE	SEAT CODE	STEM SEAL CODE	OPTION CODES
Soft Seat				
M 3 - 5 7 3			-	
M 3 - 6 7 3			-	
M 3 - 7 7 3			-	

BODY CODE	
[Std.] Carbon Steel	C
[Std.] 316 SS	S
Monel®	M
Hastelloy-C®	H

SOFT SEAT CODE	
L	Rylon® Cone [Std.]
K	Kel-F® Cone
P	PEEK® Cone
T	Teflon® Cone
D	Delrin® Cone
6	316 SS Cone

STEM SEAL CODE	
[Std.] Teflon® Pressure-Core™	T
Viton® O-Ring	V
Low-Temp Pressure-Core™	J

OPTIONS

- **Bonnet Lock Plates**
- Versa-Mount Brackets
- Bonnet Handle Lock-Out
- Steam Trace Block
- Integral Tube Fitting Connections

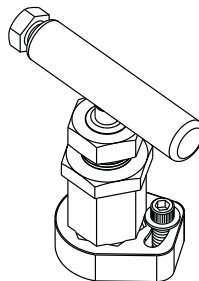

See Options/Accessories Pages 61-62.

PRESSURE & TEMPERATURE

BODY MATERIAL	SOFT SEAT (Delrin)	SOFT SEAT (Rylon)
Carbon Steel	6,000 PSI @ 200° F Max.	1,500 PSI @ 200° F Max.
316 SS	6,000 PSI @ 200° F Max.	1,500 PSI @ 200° F Max.
See Page 5:	Chart A	Chart A

OPTION CODE	OPTION DESCRIPTION
AU7	½" Integral Tube Fitting - Parker® A-LOK Dual Ferrules (Process Ports)
AV7	½" Integral Tube Fitting - Swagelok® Dual Ferrules (Process Ports)
GC	Anti-Tamper Bonnet (Isolate Valve(s) Only)
GK	Bonnet Lock-Out (Isolate Valve(s) Only - Lock Not Provided)
MD	Versa-Mount Bracket Holes (M3-673 Only)
MH	Viton® O-Ring Flange Seals
MU	Dielectric Isolation (Flange Manifolds Only)
M7	Required Slotting for Rosemount® 1151 Transmitters Series 6 & Above (Flange Manifolds Only)
PB	(2) 1/8" Constant Purge Ports (Bottom - M3-573 / 773 Only) See pg. 61 for port locations.
PS	(2) ¼" Side Purge with Plugs (M3-773 Only) See pg. 61 for port locations.
P1	Purge or Test Connections
TC	Steam Trace Block - Carbon Steel
TH	Hydrostatic Testing
TS	Steam Trace Block - 316 SS
VC	CS Versa-Mount Bracket
VS	316 SS Versa-Mount Bracket
VCH	CS Heavy-Duty Versa-Mount Bracket
VSH	316 SS Heavy-Duty Versa-Mount Bracket
W	Safety Bonnet Lock Plate
WA	CS
WAW3	300 SS
WAW9	316 SS
WK	Paper Tag
W1	316 SS Tag (20 Characters ~ See page 61)
W3	300 SS Standard Length Flange Bolts (CS Standard)
W9	316 SS Standard Length Flange Bolts (CS Standard)
XL	Clean for Critical Service (Oxygen or Chlorine)
X3	(2) ¼" Test Ports on Instrument Flange (Available on M3-773) See pg. 61 for port locations.

Two, Three & Five-Valve Integral Coplanar™ Manifolds

For Rosemount® 3051, 3095 and 2024 without Coplanar™

.125" ORIFICE

Description

1/2" FNPT x Flange

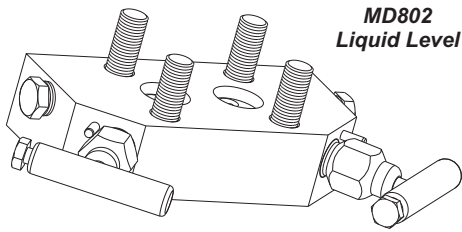

1/2" FNPT x Flange

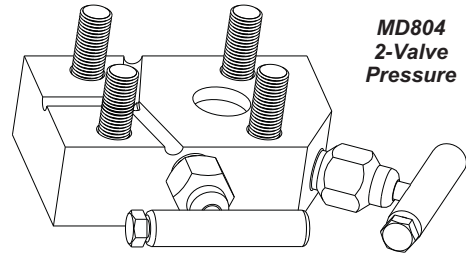

1/2" FNPT x Flange

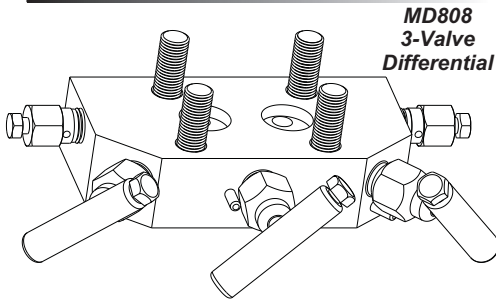

1/2" FNPT x Flange

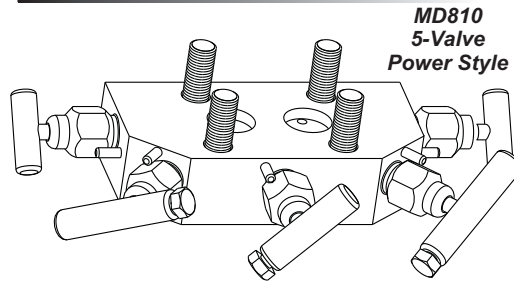

1/2" FNPT x Flange

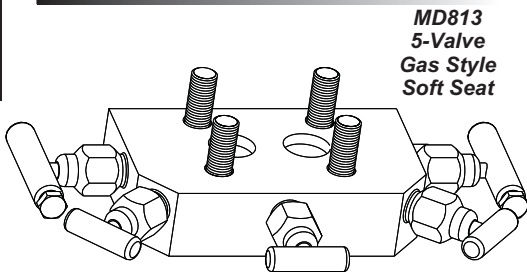

1/2" FNPT x Flange

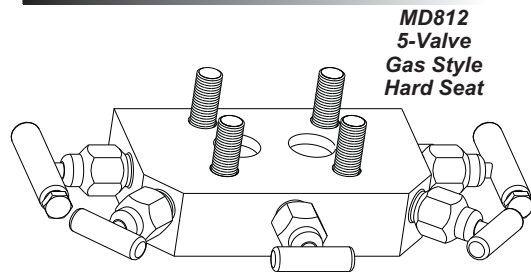

SEAT	MAX Cv RATINGS
Hard Ball	.25
Soft Cone / Washer	.25
Approx. Manifold Weight:	5.0 lbs each [MD802]
	4.3 lbs each [MD804]
	5.1 lbs each [MD808]
	5.9 lbs each [MD810]
	6.4 lbs each [MD812 / 813]

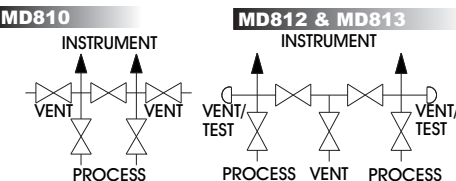
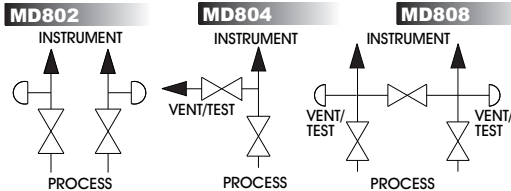

MATERIALS OF CONSTRUCTION

PART DESCRIPTION	CARBON STEEL	316 SS	MONEL®	HASTELLOY-C®
Body		ASTM A479-316 or ASTM A240-316	ASTM B164-N04405	ASTM B575-N10276 or ASTM A494 CW-12MW
Bonnet		ASTM A479-316	ASTM B164-N04405	ASTM B574-N10276
Stem	Manifold not available in Carbon Steel.	ASTM A479-316	ASTM B164-N04405	ASTM B574-N10276
Seal Retainer		ASTM A479-316	ASTM B164-N04405	ASTM B574-N10276
Handle Assembly		ASTM A582 (18-8)	ASTM A582 (18-8)	ASTM A582 (18-8)
Plug(s)		ASTM A182-F (18-8)	ASTM B164-N04405	ASTM B574-N10276
Mounting Bolts		ASTM A574	ASTM F593 (18-8)	ASTM F593 (18-8)

- 316 SS Manifolds Meet NACE MR0175 Requirements (Latest Revision)
- 100% Pressure Tested
- Coplanar™ is a trademark of Rosemount®, Inc.
- Rosemount® is a registered trademark of Rosemount®, Inc.

Two, Three & Five-Valve Integral Coplanar™ Manifolds

.125" ORIFICE

INTEGRAL COPLANAR™ MANIFOLDS

ORDERING INFORMATION

BODY STYLE	BODY CODE	SEAT CODE	STEM SEAL CODE	OPTION CODES
Hard Seat				
MD802				
MD804				
MD808				
MD810			-	
MD812			-	
Soft Seat				
MD813			-	

BODY CODE	
[Std.] 316 SS	S
Monel®	M
Hastelloy-C®	H

HARD SEAT CODE		SOFT SEAT CODE	
[Std.] Carbide Ball	C	D	Delrin® Cone / Washer [Std.]
Ceramic Ball	R	K	Kel-F® Cone / Washer
316 SS Ball	6	P	PEEK® Cone / Washer
K-Monel® Ball	N	T	Teflon® Cone / Washer
Hastelloy-C® Ball	H	Z	Tefzel Cone / Washer

STEM SEAL CODE	
[Std.] Teflon® Pressure-Core™	T
Grafoil® Packed	G
Low-Temp Pressure-Core™	J

OPTIONS

- **Steam Trace Block**
- Versa-Mount Brackets
- Bonnet Lock Plates
- Bonnet Handle Lock-Out

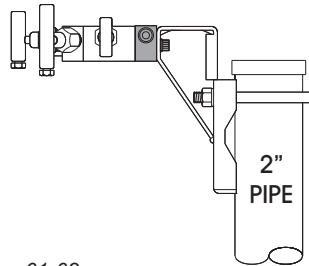

See Options/Accessories Pages 61-62.

PRESSURE & TEMPERATURE

BODY MATERIAL	HARD SEAT	HARD SEAT
	Teflon Pressure-Core	Grafoil
316 SS	6,000 PSI @ 450° F Max.	6,000 PSI @ 200° F 1,500 PSI @ 1,000° F
BODY MATERIAL	SOFT SEAT (Delrin)	
	Teflon Pressure-Core	
316 SS	6,000 PSI @ 200° F Max.	

OPTION CODE	OPTION DESCRIPTION
GA	Anti-Tamper Bonnet (All Positions)
GC	Anti-Tamper Bonnet (Isolate Valves Only)
GD	Anti-Tamper Bonnet (Equalizer Valve Only)
GJ	Bonnet Lock-Out (All Positions - Lock Not Provided)
GK	Bonnet Lock-Out (Isolate Valves Only - Lock Not Provided)
GL	Bonnet Lock-Out (Equalizer Valve Only - Lock Not Provided)
TH	Hydrostatic Testing
TS	Steam Trace Block - 316 SS
VCH	CS Heavy-Duty Versa-Mount Bracket
VSH	316 SS Heavy-Duty Versa-Mount Bracket
W	Safety Bonnet Lock Plate
WK	Paper Tag
W1	316 SS Tag (20 Characters ~ See page 61)
W3	300 SS Standard Length Flange Bolts (CS Standard)
W9	316 SS Standard Length Flange Bolts (CS Standard)
XL	Clean for Critical Service (Oxygen or Chlorine)

Purge Adapters

PATENT PENDING

Description

AK-062SCT

Flow & Level

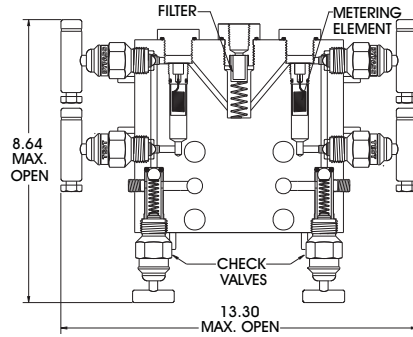
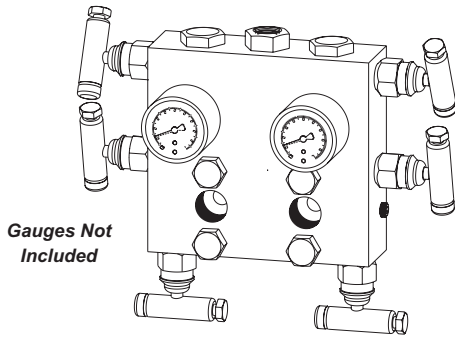

Adjustable Check Valve Option Shown

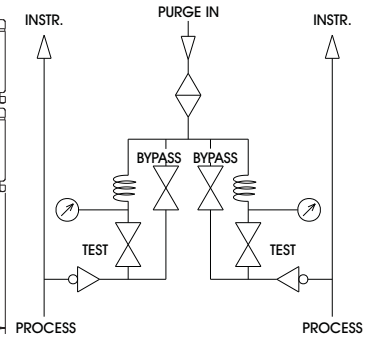

AK-064SCT

Gauge Pressure

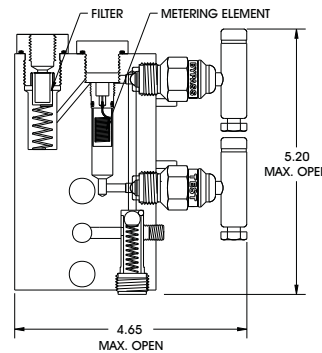
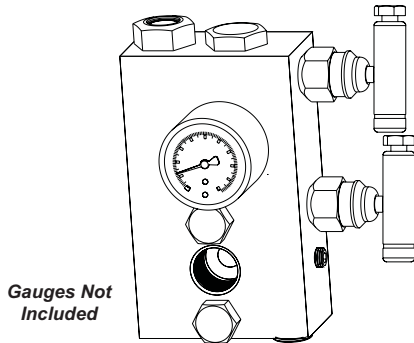

Fixed Check Valve Option Shown

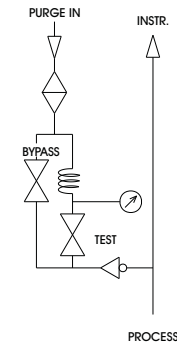

FEATURES

- Fixed constant purge for gases or liquids
- A variety of flow rates available
- Built-in test valves to test purge flows
- Built-in by-pass valves to by-pass purge metering elements in order to allow for a high flow purge into the process
- Built-in filter element to protect purge metering elements
- Optional check valves to prevent back flow of process into the purge adapter in case of purge failure or process surge
- 316 SS Body
- Tungsten Carbide® ball seats
- Teflon® Pressure-Core® Stem Seal
- ½" FNPT x Flange connections

METERING ELEMENT FLOW RATE DATA

SCFH		GPH
Capillary Flow Rates		
0.1 SCFH @ 10 PSI Air	N/A	
0.4 SCFH @ 10 PSI Air	0.3 GPH @ 25 PSI H ₂ O	
N/A	1.0 GPH @ 25 PSI H ₂ O	
Orifice Size	Orifice Flow Rates	
.016"	4 SCFH @ 10 PSI Air	2 GPH @ 25 PSI H ₂ O
.031"	19 SCFH @ 10 PSI Air	6 GPH @ 25 PSI H ₂ O
.047"	36 SCFH @ 10 PSI Air	16 GPH @ 25 PSI H ₂ O
.063"	55 SCFH @ 10 PSI Air	28 GPH @ 25 PSI H ₂ O
.078"	85 SCFH @ 10 PSI Air	42 GPH @ 25 PSI H ₂ O
.094"	110 SCFH @ 10 PSI Air	48 GPH @ 25 PSI H ₂ O

MATERIALS OF CONSTRUCTION

PART DESCRIPTION	
Body	ASTM A479-316
Bonnet	ASTM A479-316
Stem	ASTM A479-316
Seal Retainer	ASTM A479-316
Handle Assembly	ASTM A582 (18.8)
Pipe Plugs	ASTM A182-F (18.8)
Caps/Plugs	ASTM A479-316
Capillary Assembly	300 Series SS
Check Valve Assembly	300 Series SS
Filter	5 Micron Phenolic Impregnated Rayon
O-Ring Seals	Viton®

Purge Adapters

ORDERING INFORMATION

BODY STYLE	BODY CODE	SEAT CODE	STEM SEAL CODE	OPTION CODES	DESCRIPTION
Hard Seat					
AK-062				-	Differential Pressure Purge Adapter Only
AK-064				-	Static Pressure Purge Adapter Only
AK-084				-	Differential Purge Adapter, M-750SCT 3-Valve Manifold and Mounting Bracket Assembly
AK-088				-	Static Pressure Purge Adapter, M-716SCT 2-Valve Manifold and Mounting Bracket Assembly
AK-090				-	Liquid Level Purge Adapter, M-758SCT 2-Valve Liquid Level Manifold and Mounting Bracket Assembly

BODY CODE
[Std.] 316 SS S

HARD SEAT CODE	DESCRIPTION
C	Carbide Ball [Std.]
R	Ceramic Ball
6	316 SS Ball
N	K-Monel® Ball
H	Hastelloy-C® Ball

STEM SEAL CODE	DESCRIPTION
[Std.] Teflon® Pressure-Core™	T
Grafoil® Packed	G
Viton® O-Ring	V
Low-Temp Pressure-Core™	J
Teflon® Packed	P

AK-084SCT
AK-088SCT
AK-090SCT
Assemblies

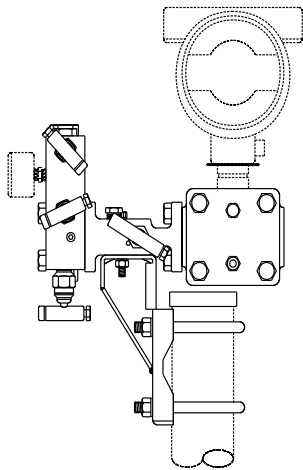

OPTION CODE	OPTION DESCRIPTION
C3	EPDM O-Rings
CC	Adjustable Check Valve(s)
CD	Non-Adjustable Check Valve(s)
CF	0.1 SCFH Capillary Assembly
CG	1.0 GPH Capillary Assembly
CK	0.4 SCFH / .3 GPH Capillary Assembly
CHXXX	Orifice Assembly XXX = Orifice Size (Choose .016", .031", .047", .063", .078" or .094" as referenced on page 51)
CJ	7 Micron Filter, Sintered 316 SS
CE	Anit-Tamper Device on all Vent/Test Bonnets

PRESSURE & TEMPERATURE

BODY MATERIAL	HARD SEAT Teflon Pressure-Core	HARD SEAT Grafoil
316 SS	6,000 PSI @ 400° F	6,000 PSI @ 400° F

Direct-Mount™ Systems for UltraSonic Flow Meters

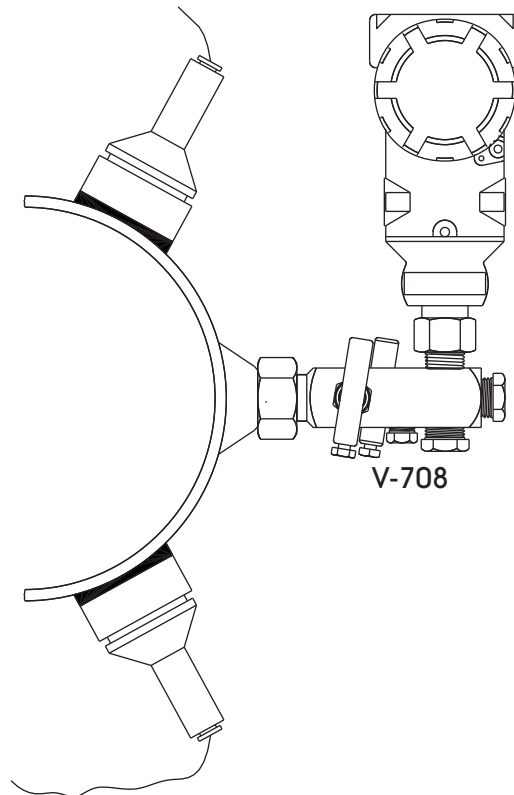
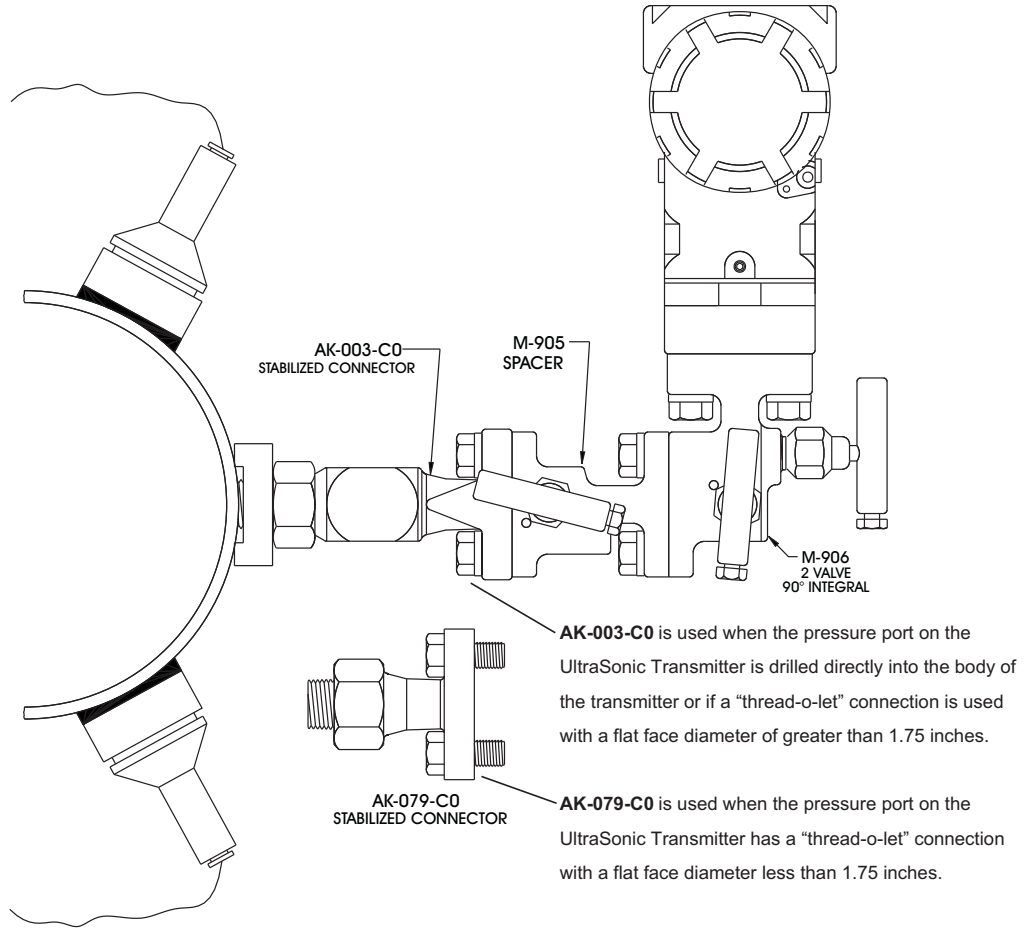

Direct-Mount™ Systems for UltraSonic Flow Meters

ORDERING INFORMATION

BODY STYLE	BODY CODE	SEAT CODE	STEM SEAL CODE	OPTION CODES			
Hard Seat							
M-905			-				
M-906			-				
V-708			-				
Stabilized Connectors ~ 75 ft./lbs. with CS Bolts							
AK-003-C0			-				
AK-079-C0			-				

BODY CODE	
[Std.] 316 SS	S

HARD SEAT CODE	
C	Carbide Ball [Std.]
R	Ceramic Ball
6	316 SS Ball

STEM SEAL CODE	
[Std.] Teflon® Pressure-Core™	T
Grafoil® Packed	G
Low-Temp Pressure-Core™	J

OPTION CODE	OPTION DESCRIPTION
GA	Anti-Tamper Bonnet (All Positions)
GC	Anti-Tamper Bonnet (Isolate Valve(s) Only)
GE	Anti-Tamper Bonnet (Vent Valve Only - M-906 & V-708 Only)
GJ	Bonnet Lock-Out (All Positions - Lock Not Provided)
GK	Bonnet Lock-Out (Isolate Valve(s) Only - Lock Not Provided)
GM	Bonnet Lock-Out (Vent Valve Only - Lock Not Provided - M-906 & V-708 Only)
MH	Viton® O-Ring Flange Seals (M-905/906 Only)
•MJ	Viton® O-Ring Flange Seal (AK-003/079-CO Only)
•MN	Dielectric Isolation (AK-003/079-CO Only)
MU	Dielectric Isolation (M-905/906 Only)
M7	Required Slotting for Rosemount® 1151 Transmitters Series 6 & Above (M-906 Only)
TH	Hydrostatic Testing
TS	Steam Trace Block - 316 SS (M-905 & M-906 Only)
W	Safety Bonnet Lock Plate
WA	CS
WAW3	300 SS
WAW9	316 SS
WK	Paper Tag
W1	316 SS Tag (20 Characters ~ See page 61)
W3	300 SS Standard Length Flange Bolts (CS Standard)
W9	316 SS Standard Length Flange Bolts (CS Standard)
XL	Clean for Critical Service (Oxygen or Chlorine)
• AK-003-C0 or AK-079-C0 Can Only Use These Designated Options.	

PRESSURE & TEMPERATURE

BODY MATERIAL	HARD SEAT	HARD SEAT
	Teflon Pressure-Core	Grafoil
316 SS	10,000 PSI @ 200° F	6,000 PSI @ 200° F
	8,000 PSI @ 400° F	1,500 PSI @ 1,000° F
See Page 5:	Chart D	Chart F

Gauge Siphons and Swivels

The PGI Gauge Siphon replaces the old style "Pigtail" siphon. The siphon provides a thermal barrier, protecting your instruments from harmful vapors. The siphon also reduces gauge whip, allowing closer process installation. The siphon can be used as either a freeze or steam protector when used with the proper fill fluids.

When very high heat is present, the siphon, used in conjunction with the PGI V-506 Grafoil Packed Hand Valve, reduces temperatures seen at the instrument by lengthening the condensate leg.

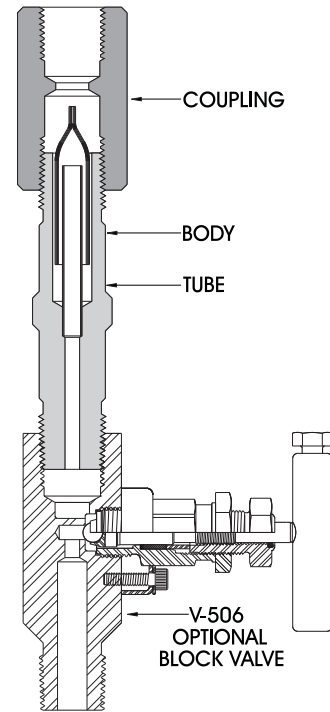

Gauge Siphons

PART NO.	CONNECTIONS		BODY	COUPLING	TUBE
	INLET	OUTLET			
Gauge Siphons					
A7-524-C0	1/2" MNPT x 1/2" FNPT		316 SS	CS	316 SS
A7-524-C0S			316 SS	316 SS	316 SS
A7-508-C0	3/4" MNPT x 3/4" FNPT		316 SS	CS	316 SS
A7-508-C0S			316 SS	316 SS	316 SS
Gauge Siphons with Excess Flow Check					
A7-509-C0	1/2" MNPT x 1/2" FNPT		316 SS		
Gauge Siphons with Excess Flow Check and Swivels					
A7-507-C0	1/2" MNPT x 1/2" FNPT		316 SS		
Gauge Swivel					
A7-530-C0	1/2" MNPT x 1/2" FNP		316 SS		
A7-530-K0			Monel		

Hand Block Valve

PART NO.	CONNECTIONS		BODY & BONNET	PACKING	SEAT
	INLET	OUTLET			
V-506CCG	1/2" MNPT x 1/2" FNPT		ASTM A105 CF	Grafoil®	Carbide Ball
V-506SCG			ASTM A479-316 SS		

A7-507

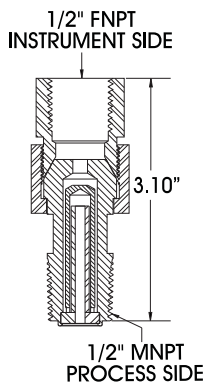

A7-509

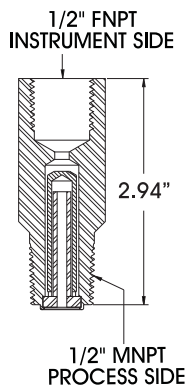

A7-530

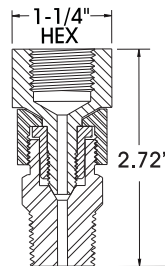

A7-524

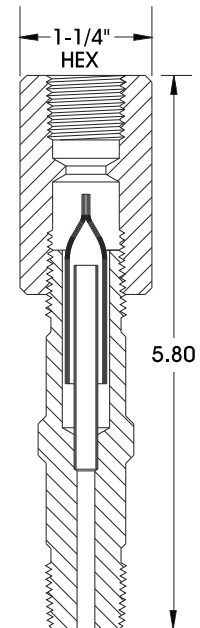

Teflon® Mini Pressure-Core™ Stem Seal Bonnet and Packing Design

.136" ORIFICE

P A T E N T E D

.136" Orifice

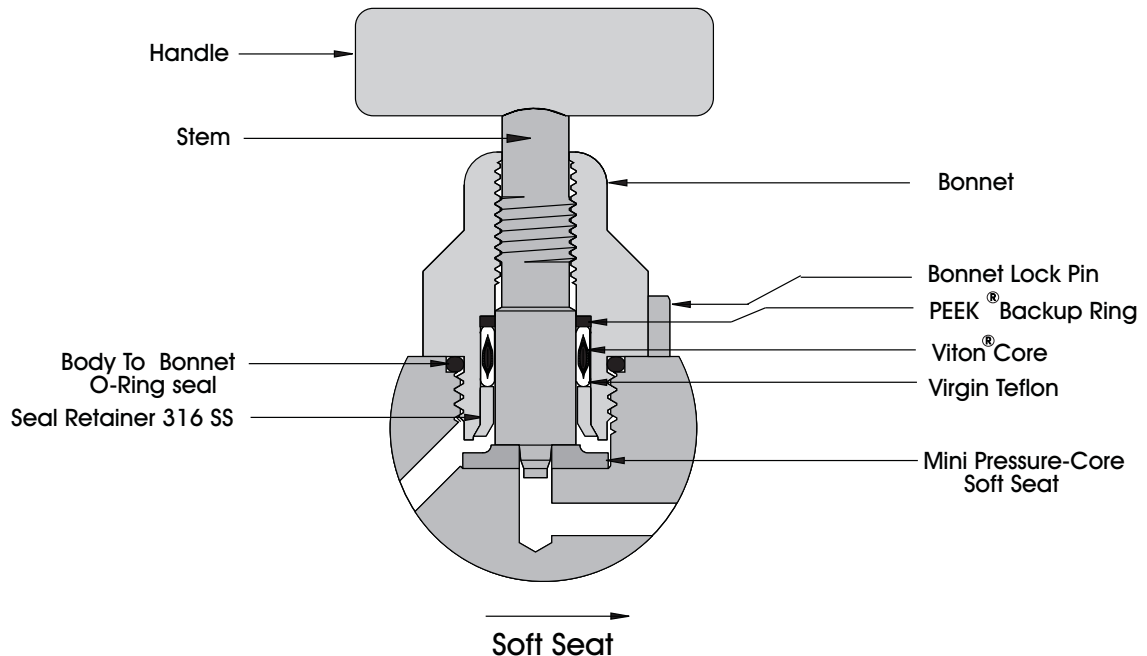

CODE "T"

Mini Teflon Pressure-Core vs. Conventional "Packed" Teflon®

Conventional mini packed bonnet designs are prone to stem leaks due to Teflon® seal extrusion. The packing is located above the stem threads, thus allowing the possibility of critical stem thread contamination by the process. Additionally, the soft seat area is so small that technicians can easily force the stem through the seat washer as they try to get a "firm feel" on the shut-off. Over the long run, stem and seat leaks will cause calibration and recording difficulties, as well as loss of sample product.

Mini Pressure-Core Advantages:

- HIGHLY RELIABLE Patented Pressure-Core™ Stem Seal with 5 YEAR WARRANTY
- Seal BELOW the Stem Threads
- Soft Seat Washer with FOUR TIMES the Sealing Area of a Standard Mini Seat that Provides a Seat that Can't Be Damaged with Excessive Shutoff Force
- SAME Cv RATING (.22 Max) as the Conventional Mini Bonnet

Teflon® Pressure-Core™ Stem Seal Bonnet and Packing Design

.187" .250" .375" ORIFICE

P A T E N T E D

.187" .250" Orifice

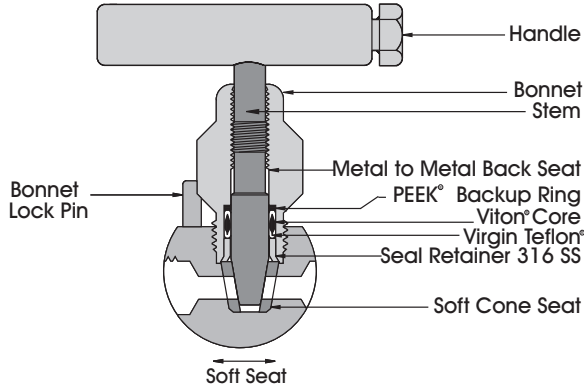

.187" Orifice Only

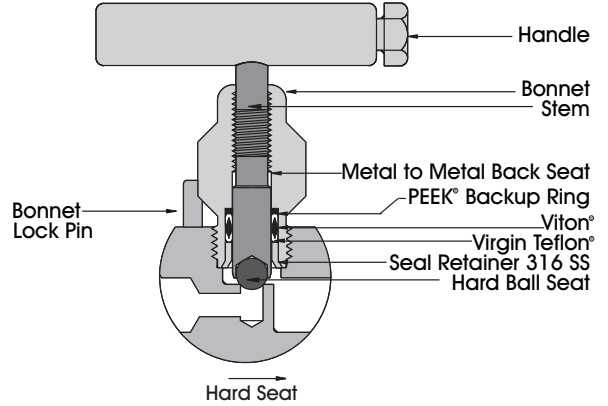

.375" Orifice

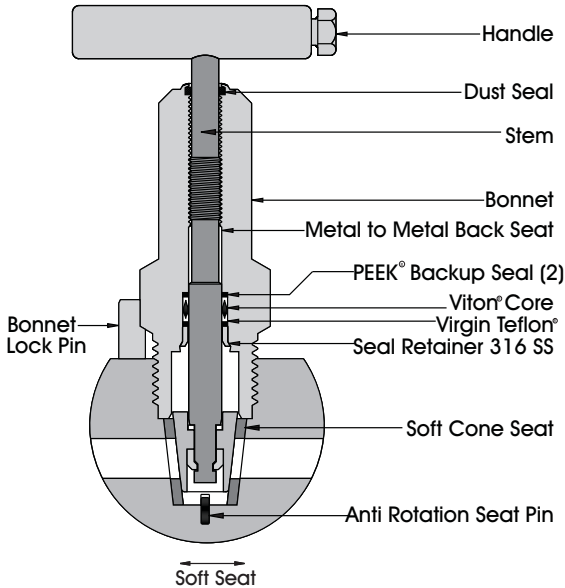

.375" Orifice

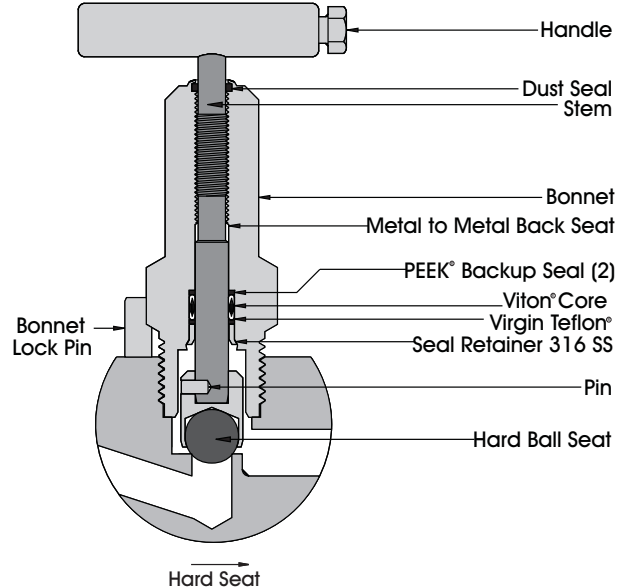

Viton® O-Ring Bonnet Design

.125" .136" .187" .250" .375" ORIFICE

CODE "V"

.125" Orifice

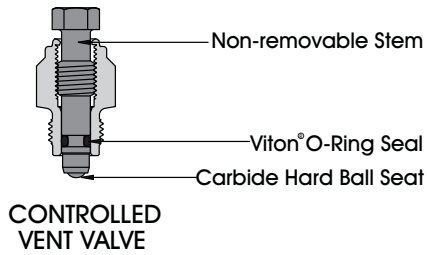

.136" Orifice

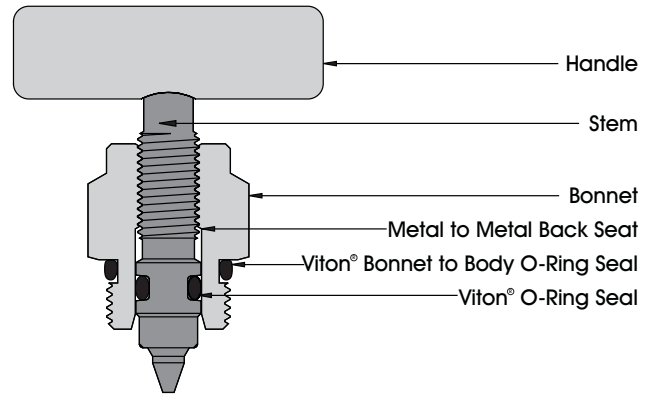

.187" .250" Orifice

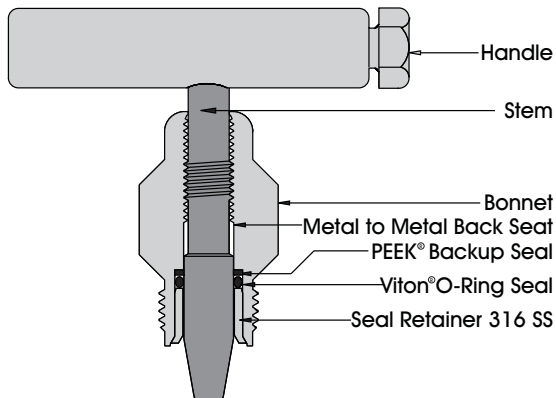

.375" Orifice

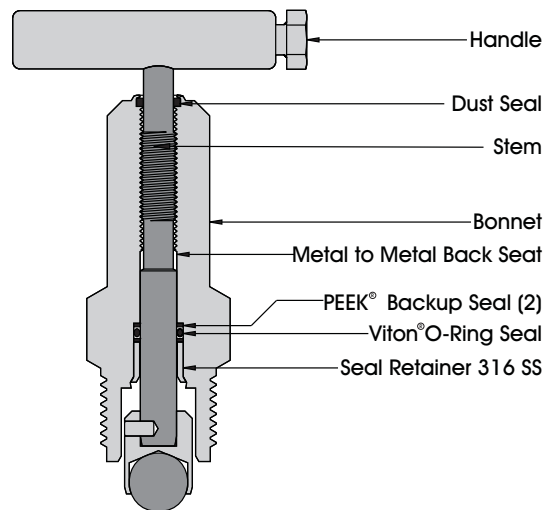

Adjustable Packed Bonnet Designs ~ Bonnet and Packing Design

.136" .187" .375" ORIFICE

Packed Mini Valves Teflon® Code "T"

.136" Orifice

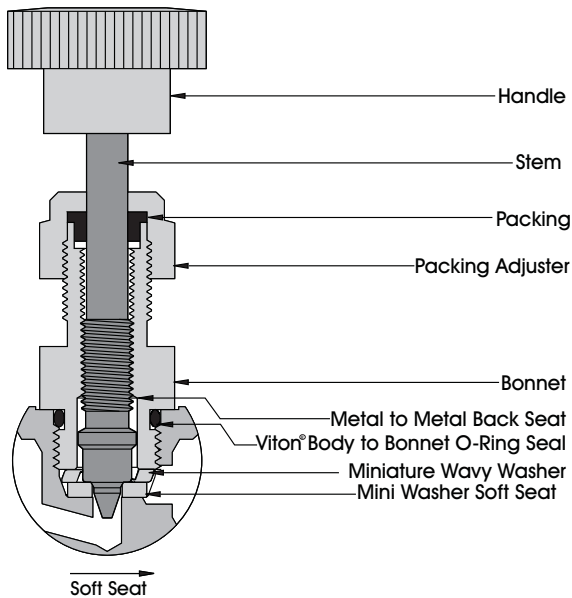

.136" Orifice

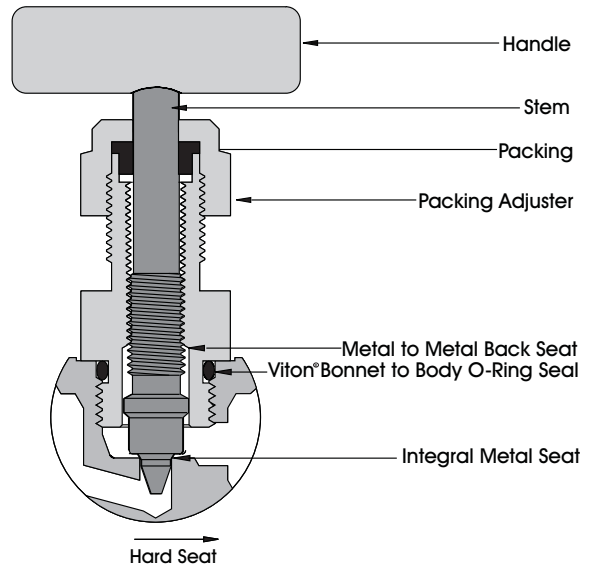

Packed Valves Teflon® Code "P" Grafoil® Code "G"

.187" Orifice

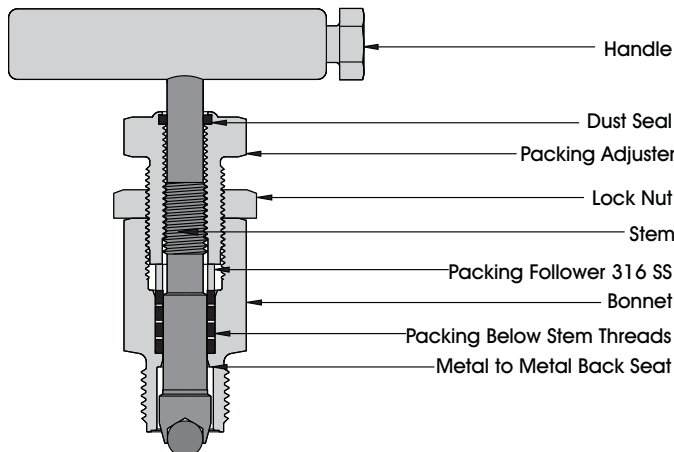

.375" Orifice

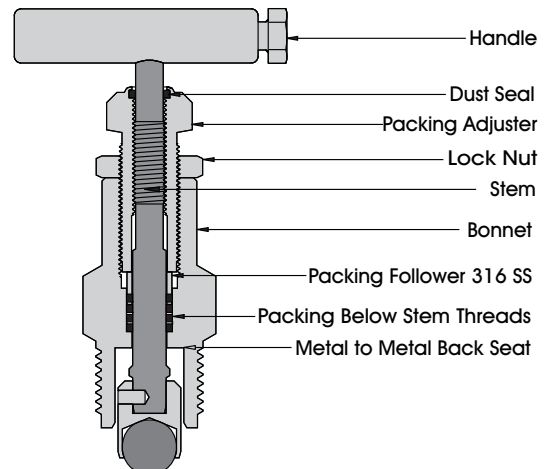

OS & Y Bonnet Code "Y"

Packings

Teflon® Code "P" Grafoil® Code "G"

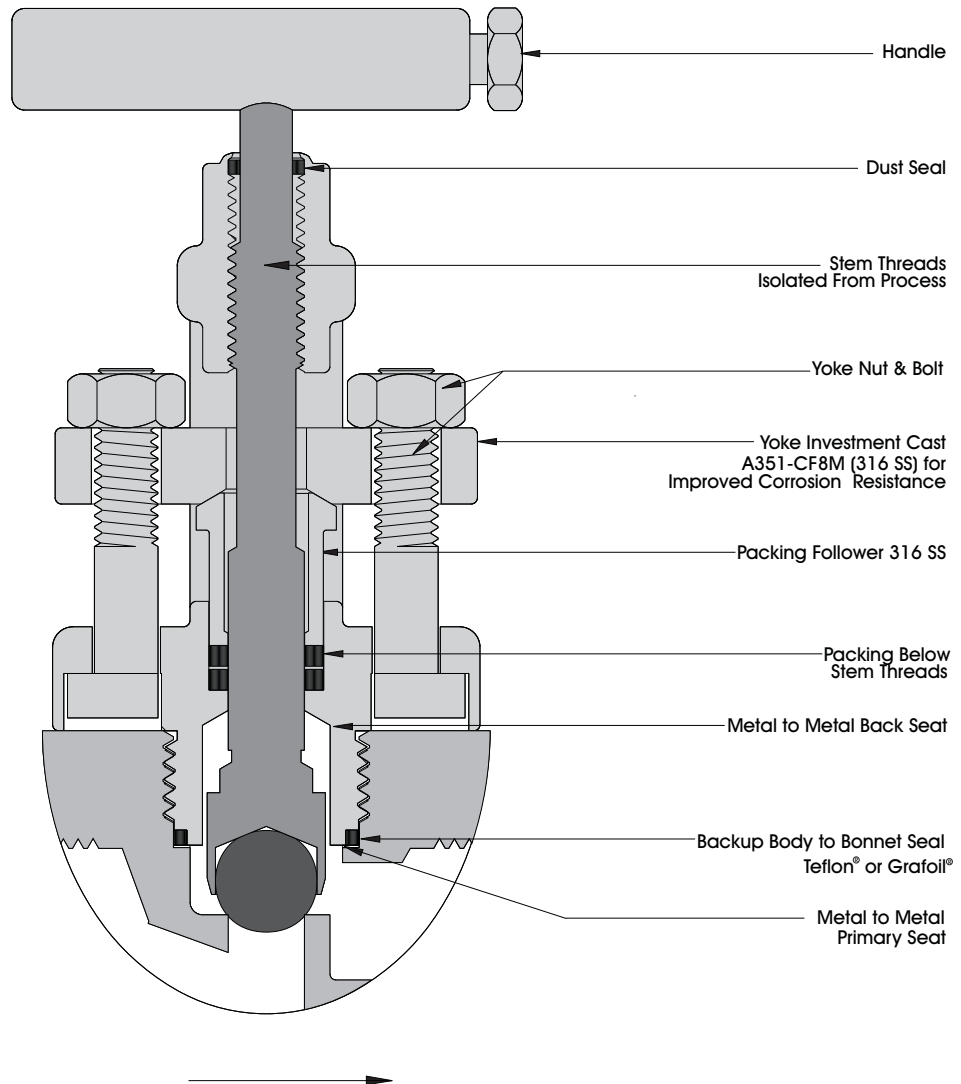

Options

Bonnet Lock Plate

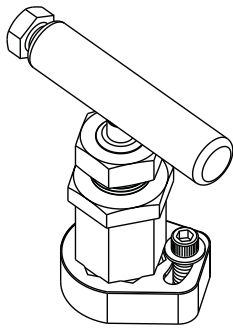

The Bonnet Lock Plate provides a more positive bonnet-locking device than the standard roll pin.



Anti-Tamper Bonnet

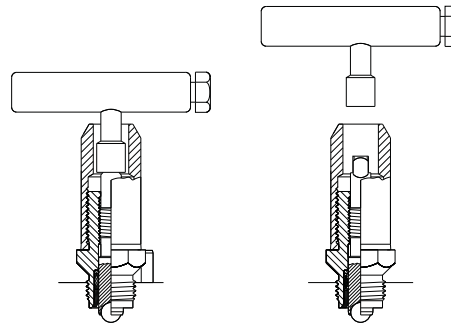

The Anti-Tamper Bonnet Handle allows the bonnet stem to be placed in any position, including open or close, before removing the handle. Without the handle, it is virtually impossible to operate the valve.

Bonnet Handle Lock-out

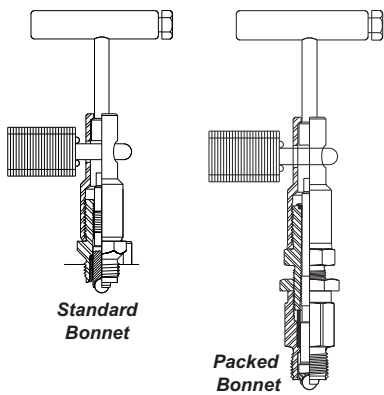

The Bonnet Handle Lock-out is similar to the Anti-Tamper Bonnet Handle. The bonnet stem is placed in its desired position, the handle is then raised, and the lock installed. The handle cannot be removed, and therefore cannot be lost.

Integral Tube Fitting Connection

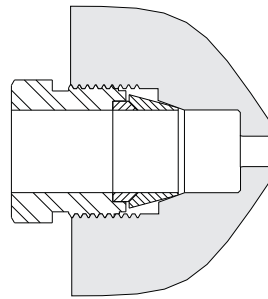

The Integral Tube Fitting Connection is available in 1/2" tube only. It is optional on most manifolds and needle valves. Specify the Integral Tube Fitting Connection option to select a system which eliminates pipe threads. A variety of ferrules are available.

.187" Orifice

PART NUMBER	DESCRIPTION	BONNET MATERIAL	SEAT	STEM SEAL
SAV161SCT	Anti-Tamper Bonnet	316 SS	Carbide Ball	Teflon® Pressure-Core™
SAV166S-T	Anti-Tamper Bonnet	316 SS	Soft Cone	Teflon® Pressure-Core™
AK-123-C0	Anti-Tamper Handle Only	316 SS	---	---
SAV164SCT	Bonnet Handle Lock-out	316 SS	Carbide Ball	Teflon® Pressure-Core™
SAV165S-T	Bonnet Handle Lock-out	316 SS	Soft Cone	Teflon® Pressure-Core™

.375" Orifice

SAV305SCT	Bonnet Handle Lock-out	316 SS	Carbide Ball	Teflon® Pressure-Core™
SAV305S-T	Bonnet Handle Lock-out	316 SS	Soft Cone	Teflon® Pressure-Core™

Purge Port Locations

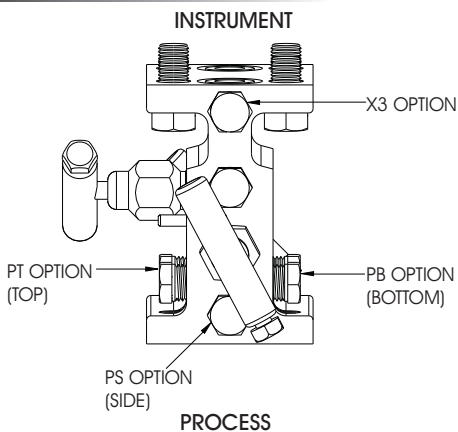

316 Stainless Steel Tag ~ Option Code W1

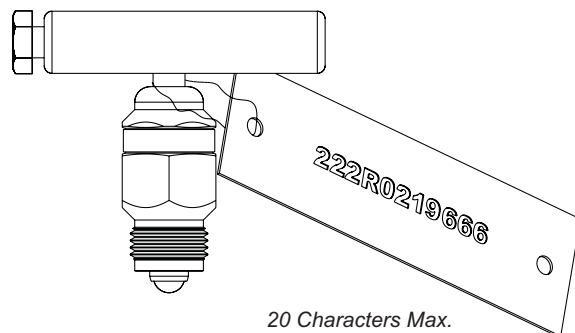

Accessories and Kits

AK-002-__ : Versa-Mount Manifold Brackets

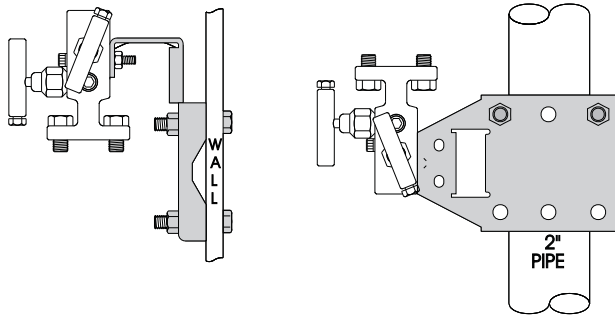

AK-002-__ - HD: Heavy-Duty Versa-Mount Manifold Brackets

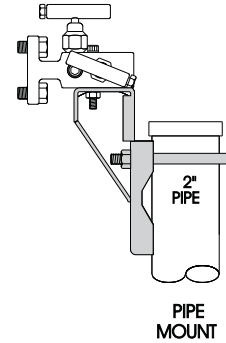

AK-085-C0: Coplanar™ Mounting Adapter Plate

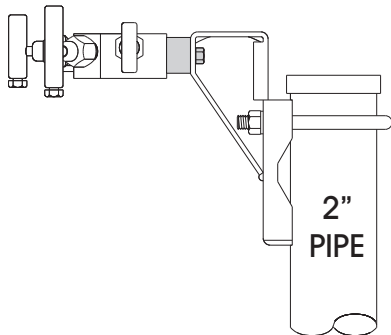

AK-032-__ - __ : Manifold Dielectric Kits

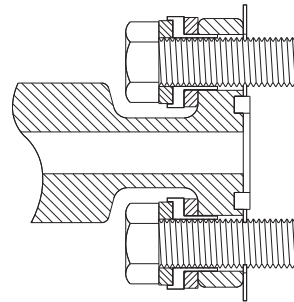

AK-__ : Steam Trace Block

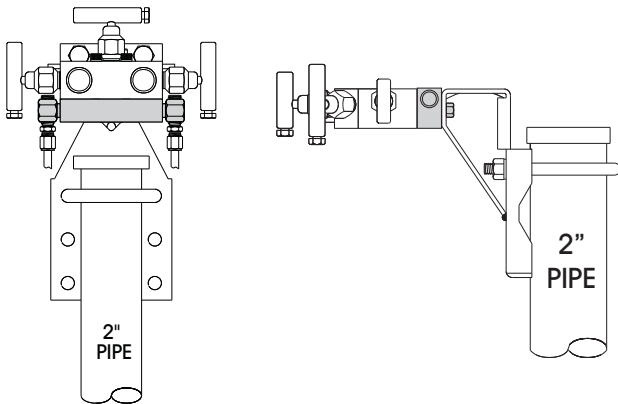

AK-__ : Dual Steam Trace Block

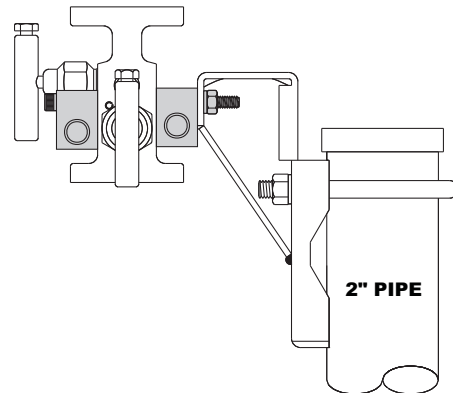

AK-099-10: Versa-Mount Side Adapter

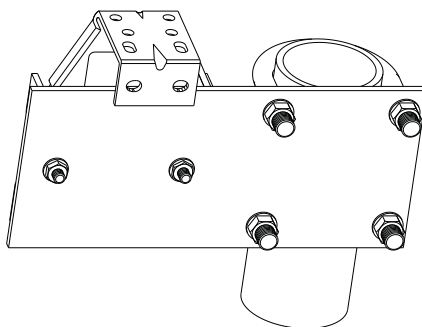

This bracket allows the transmitter to be mounted off set to the mounting post.

AK-010-__ : Flange Adapters

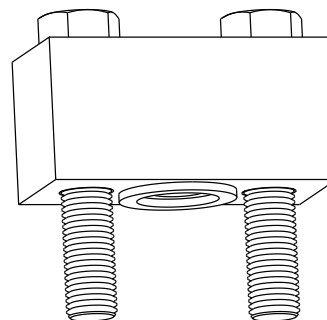

These adapters can be mounted on the process side of our flange to flange manifolds.

Accessories and Kits

Accessories

PART NUMBER	DESCRIPTION	MATERIAL
Flange Adapters, Brackets and Hex Nipples		
AK-010-10	Flange Adapter - Includes (2) ½" NPT Flange Adapters, (4) Bolts, (2) Teflon® Seals	Carbon Steel
AK-010-C0	Flange Adapter - Includes (2) ½" NPT Flange Adapters, (4) Bolts, (2) Teflon® Seals	316 SS
AK-034-10	Conduit / Purge Meter Bracket	Carbon Steel
AK-035-10	Dual Conduit / Purge Meter Bracket	Carbon Steel
AK-099-10	Versa-Mount with Side Adapter Kit	Carbon Steel
C4-008-10	½" NPT Concentric Hex Nipple - 3" Long	Carbon Steel
C4-008-C0	½" NPT Concentric Hex Nipple - 3" Long	316 SS
C4-009-10	½" NPT Eccentric Hex Nipple - 3" Long	Carbon Steel
C4-009-C0	½" NPT Eccentric Hex Nipple - 3" Long	316 SS
Manifold Mounting Brackets & Accessories		
AK-002-10	Versa-Mount Manifold Mounting Bracket [VC Option Code]	Carbon Steel
AK-002-C0	Versa-Mount Manifold Mounting Bracket [VS Option Code]	316 SS
AK-002-10-HD	Versa-Mount Manifold Mounting Bracket (Heavy-Duty) [VCH Option Code]	Carbon Steel
AK-002-C0-HD	Versa-Mount Manifold Mounting Bracket (Heavy-Duty) [VSH Option Code]	316 SS
AK-002-10-HDWL	Versa-Mount Manifold Mounting Bracket (Heavy-Duty) w/ 2 Mounting U-Bolts [VCHWL Option Code]	Carbon Steel
AK-085-C0	Coplanar™ Mounting Adapter Plate	316 SS
Steam Trace Block		
AK-006-10	Steam Trace Block for Conventional 3 Valve Manifolds [TC Option Code]	Carbon Steel
AK-006-C0	Steam Trace Block for Conventional 3 Valve Manifolds [TS Option Code]	316 SS
AK-007-10	Steam Trace Block for Conventional 2 and 5 Valve Manifolds [TC Option Code]	Carbon Steel
AK-007-C0	Steam Trace Block for Conventional 2 and 5 Valve Manifolds [TS Option Code]	316 SS
AK-110-C0	Steam Trace Block for M-616 Slim Body 2 Valve Pressure Manifold [TS Option Code]	316 SS
AK-111-C0	Steam Trace Block for MD804, MD808, MD810, MD812 & MD813 Coplanar™ Manifolds [TS Option Code]	316 SS
Pipe Plugs		
P6-024-10	½" NPT Allen Head	Carbon Steel
P6-024-C0	½" NPT Allen Head	316 SS
P6-024-K0	½" NPT Allen Head	Monel®
P6-036-10	¼" NPT Hex Head	Carbon Steel
P6-036-C0	¼" NPT Hex Head	316 SS
P6-062-10	½" NPT Hex Head	Carbon Steel
P6-062-C0	½" NPT Hex Head	316 SS

Kits

PART NUMBER	DESCRIPTION	MATERIAL
Manifold Flange Seal Kits		
P5-018-R0	Manifold Flange Seal	Teflon®
P5-018-R1	Manifold Flange Seal	Grafoil®
P5-027-R0	Manifold Flange Seal for M-660 Manifold	Teflon®
P5-027-R1	Manifold Flange Seal for M-660 Manifold	Grafoil®
P5-046-R0	Manifold Flange Seal when used with Dielectric Isolators	Teflon®
P5-075-R0	Viton® O-Ring Flange Seal	Viton®
Manifold Dielectric Kits (1 kit per Manifold)		
AK-032-C0	Dielectric Gasket / CS Bolts / 316 SS Washers / Bolt Sleeves	
AK-032-C0-W3	Dielectric Gasket / 300 SS Bolts / 316 SS Washers / Bolt Sleeves	
AK-032-C0-W9	Dielectric Gasket / 316 SS Bolts / 316 SS Washers / Bolt Sleeves	

Spare Parts

.136" ORIFICE SEATS		.136" ORIFICE BONNET PACKING	
PART NO.	DESCRIPTION	PART NO.	DESCRIPTION
SP5-020-R0	Mini Teflon® Seat	SP5-019-R0	Mini Packed Teflon® Seal
SP5-020-R1	Mini Kel-F® Seat	SP5-047-R0	Mini Packed Grafoil® Seal
SP5-020-R2	Mini Delrin® Seat	SP7-025-C0	Stainless Steel Backup Washer
SP5-020-R3	Mini PEEK® Seat	.136" ORIFICE BONNET ASSEMBLIES	
SP7-024-C0	Wavey Washer	PART NO.	DESCRIPTION
SP3-010-R3	Mini Pressure-Core™ Delrin® Seat	SAV106C-V	Carbon Steel with Viton® Packing
SP3-010-R2	Mini Pressure-Core™ Teflon® Seat	SAV106S-V	Stainless Steel with Viton® Packing
SP3-010-R4	Mini Pressure-Core™ PEEK® Seat	SAV107C-T	Carbon Steel with Packed Teflon®
SP3-010-R9	Mini Pressure-Core™ Tefzel Seat	SAV107S-T	Stainless Steel with Packed Teflon®
.136" ORIFICE HANDLES		SAV117C-T-H3	Carbon Steel w/ Teflon® Mini Pressure-Core™
PART NO.	DESCRIPTION	SAV117S-T-H4	Stainless Steel w/ Teflon® Mini Pressure-Core™
SAV-001-10	Round Handle - Carbon Steel	SAV117C-J-H3	Carbon Steel w/ Low-Temp Teflon® Mini Pressure-Core™
SAV-002-10	Bar Handle - Carbon Steel	SAV117S-J-H4	Stainless Steel w/ Low-Temp Teflon® Mini Pressure-Core™
SAV-002-A0	Bar Handle - Stainless Steel	SAV119C-V-H3	Carbon Steel w/ Viton® O-Ring
SAV-003-R0	Round Handle - Plastic	SAV119S-V-H4	Stainless Steel w/ Viton® O-Ring

.187" ORIFICE SEATS		.187" ORIFICE BONNET ASSEMBLIES			
PART NO.	DESCRIPTION	PART NO.	STEM SEAL	SEAT	BONNET MATERIAL
SP3-003-R1	Kel-F® Cone Seat	SAV100CCV	Viton®	Carbide Ball	Carbon Steel
SP3-003-R2	PEEK® Cone Seat	SAV100CCT	Teflon® Pressure-Core™		
		SAV100CCJ	Low-Temp Teflon® Pressure-Core™		
SP3-003-R3	Teflon® Cone Seat	SAV100SCV	Viton®	Carbide Ball	316 SS
SP3-003-R4	Delrin® Cone Seat	SAV100SCT	Teflon® Pressure-Core™		
SP3-003-R9	Tefzel Cone Seat	SAV100SCJ	Low-Temp Teflon® Pressure-Core™		
		SAV144SCG-HH	Grafoil®	Soft Cone	Carbon Steel
		SAV101C-V	Viton®		
		SAV101C-T	Teflon® Pressure-Core™		
		SAV101C-J	Low-Temp Teflon® Pressure-Core™	Soft Cone	316 SS
		SAV101S-V	Viton®		
		SAV101S-T	Teflon® Pressure-Core™		
.187" ORIFICE OS & Y BONNET ASSEMBLIES					
PART NO.	STEM SEAL	SEAT	BONNET MATERIAL		
SAV202SCG-HH	Grafoil® Packed	Carbide Ball	316 SS		

.250" ORIFICE SEATS		.250" ORIFICE PRESSURE-CORE™ BONNET ASSEMBLIES			
PART NO.	DESCRIPTION	PART NO.	STEM SEAL	SEAT	BONNET MATERIAL
SP3-012-R4	Delrin® Cone Seat	SAV123C-T-HH	Teflon® Pressure-Core™	Soft Cone	Carbon Steel
SP3-012-R1	Kel-F® Cone Seat	SAV123C-J-HH	Low-Temp Teflon® Pressure-Core™		
SP3-012-R2	PEEK® Cone Seat	SAV123S-T-HH	Teflon® Pressure-Core™	Soft Cone	316 SS
		SAV123S-J-HH	Low-Temp Teflon® Pressure-Core™		

.375" ORIFICE SEATS		.375" ORIFICE PRESSURE-CORE™ BONNET ASSEMBLIES			
PART NO.	DESCRIPTION	PART NO.	STEM SEAL	SEAT	BONNET MATERIAL
SP3-007-R1	Kel-F® Cone Seat	SAV300CCT-HH	Teflon® Pressure-Core™	Carbide Ball	Carbon Steel
SP3-007-R2	PEEK® Cone Seat	SAV300CCJ-HH	Low-Temp Teflon® Pressure-Core™		
SP3-007-R3	Teflon® Cone Seat	SAV300SCT-HH	Teflon® Pressure-Core™		
SP3-007-R4	Delrin® Cone Seat	SAV300SCJ-HH	Low-Temp Teflon® Pressure-Core™	Soft Cone	Carbon Steel
SP3-007-R8	Rylon® Cone Seat	SAV300C-T-HH	Teflon® Pressure-Core™		
		SAV300C-J-HH	Low-Temp Teflon® Pressure-Core™		
		SAV300S-T-HH	Teflon® Pressure-Core™	Soft Cone	316 SS
		SAV300S-J-HH	Low-Temp Teflon® Pressure-Core™		

.375" ORIFICE OS & Y BONNET ASSEMBLIES			
PART NO.	STEM SEAL	SEAT	BONNET MATERIAL
SAV200SCG-HH	Grafoil® Packed	Carbide Ball	316 SS
SAV200S-G-HH	Grafoil® Packed	Cone Seat	316 SS

.375" ORIFICE PACKED STYLE BONNET ASSEMBLIES			
PART NO.	STEM SEAL	SEAT	BONNET MATERIAL
SAV301SCG-HH	Grafoil® Packed	Carbide Ball	316 SS
SAV301S-G-HH	Grafoil® Packed	Cone Seat	316 SS

Note: Handle included in all Bonnet Assemblies.

Individual Bolt Chart

Individual Hex Head Bolt Part Number Chart

PART NUMBER	BOLT LENGTH	MATERIAL 7/16-20 THREAD	OPTION CODE	PART NUMBER	BOLT LENGTH	MATERIAL 7/16-20 THREAD	OPTION CODE
P6-057-10	3/4"	CS	WV	P6-086-10	3"	CS	WF
P6-057-A0		300 SS		P6-086-A0		300 SS	
P6-057-C0		316 SS		P6-086-C0		316 SS	
P6-067-10	1"	CS	WG	P6-089-10	3-1/4"	CS	WJ
P6-067-A0		300 SS		P6-089-A0		300 SS	
P6-067-C0		316 SS		P6-089-C0		316 SS	
P6-073-10	1-1/4"	CS	W7	P6-107-10	3-1/2"	CS	WQ
P6-073-A0		300 SS		P6-107-A0		300 SS	
P6-073-C0		316 SS		P6-107-C0		316 SS	
P6-058-10	1-1/2"	CS	WB	P6-149-10	3-3/4"	CS	WS
P6-058-A0		300 SS		P6-149-A0		300 SS	
P6-058-C0		316 SS		P6-149-C0		316 SS	
P6-028-10	1-3/4"	CS	WH	P6-108-10	4"	CS	WN
P6-028-A0		300 SS		P6-108-A0		300 SS	
P6-028-C0		316 SS		P6-108-C0		316 SS	
P6-061-10	2"	CS	WC	P6-102-10	4-1/4"	CS	WP
P6-061-A0		300 SS		P6-102-A0		300 SS	
P6-061-C0		316 SS		P6-102-C0		316 SS	
P6-029-10	2-1/4"	CS	WA	P6-109-10	4-1/2"	CS	WR
P6-029-A0		300 SS		P6-109-A0		300 SS	
P6-029-C0		316 SS		P6-109-C0		316 SS	
P6-080-10	2-1/2"	CS	WE	P6-197-10	4-3/4"	CS	WT
P6-080-A0		300 SS		P6-197-A0		300 SS	
P6-080-C0		316 SS		P6-197-C0		316 SS	
P6-038-10	2-3/4"	CS	WD	P6-002-10	5-1/4"	CS	WU
P6-038-A0		300 SS		P6-002-A0		300 SS	
P6-038-C0		316 SS		P6-002-C0		316 SS	

Hex Head Bolt Washers

PART NUMBER	DESCRIPTION
P6-090-A0	316 SS Bolt Washer (For Slotted Flange Manifolds)
P6-090-10	Carbon Steel Bolt Washer (For Slotted Flange Manifolds)

"MD" Coplanar™ Manifolds Individual Allen Head Bolt Part Number

PART NUMBER	DESCRIPTION
P6-145-10	7/16-20 x 1-3/4" MD Manifolds (1.3 Centers) - Carbon Steel
P6-145-A0	7/16-20 x 1-3/4" MD Manifolds (1.3 Centers) - 300 SS
P6-145-C0	7/16-20 x 1-3/4" MD Manifolds (1.3 Centers) - 316 SS

Warranty, Sales Policy, Special Orders and Oxygen & Chlorine Service

Product Warranty

PGI International warrants its products to be free from defects in material and/or workmanship for a period of one year from date of shipment. This guarantee is valid only if such products have been used in normal applications consistent with our recommendations. Our liability is limited to repair or replacement and no responsibility is assumed for consequential damage or expense. Any controversy arising out of the sale of PGI International products shall be determined in accordance with laws of the State of Texas.

PGI International reserves the right to change materials, specifications or designs without notice. PGI International will not be obligated to install or furnish such changes on products previously or subsequently sold.

Teflon® Pressure-Core® Stem Seal Warranty

After years of field experience and over one million valves in service, PGI International takes great pride in extending a five year limited warranty on our patented Teflon® Pressure-Core® Stem Seal System. The warranty period starts at date of purchase and extends for five full years. If within this period the Pressure-Core® Stem Seal develops a leak, PGI will provide a new bonnet and stem assembly at no cost.

PGI International will assume no consequential damages or liabilities connected with this warranty. The warranty is void if the valves have not been used in accordance with the stamped pressure / temperature ratings or if the bonnet assembly has been disassembled. The Teflon® Pressure-Core® Stem Seal is factory assembled and cannot be disassembled or inspected without damaging the seal.

Sales Policy

Our products are sold through authorized manufacturer representatives or direct from our factory sales office. All orders are subject to acceptance by PGI International, headquarters located in Houston, Texas (U.S.A.). Prices are subject to change without notice and any errors in published prices are subject to correction. No materials may be returned for credit without written authorization from our Houston office. In issuing credit for returned material, we reserve the right to direct deduct a reconditioning and handling charge. Special items, not conforming to our standard line, will not be accepted for credit.

Special Orders

PGI International has been a custom manufacturer of valve components since 1941. PGI invites inquiries for special variations on our line of valves and will work with you to solve your specific application problems.

Oxygen & Chlorine Service

To insure the quality, safety and cleanliness levels of our products, PGI International has a verifiable, environmentally controlled system of precision cleaning for Oxygen and Chlorine Service.

- Parts are cleaned with an approved liquid cleaner in an ultrasonic vibrator.
- Inspection of parts is done with an Ultraviolet light to detect contaminants such as hydrocarbons and minute particles that are not visible to the naked eye.
- Each part is tagged and heat-sealed in a double bag to prevent contamination in transit.
- **Upon completion of cleaning process, Carbon Steel Manifolds discolor to a silver-greenish sheen. This does not affect manifold performance in any way.**

INSTRUMENTATION PRODUCTS

Instrument Valves & Manifolds
Power and Steam Plant Valves & Manifolds
Purge Adapters for the Process Industry

SPECIALIZED SYSTEMS

Gas & Liquid Sampling Systems
Natural Gas Sampling System Heated Enclosures
Sample Cylinders and Accessories

MEASUREMENT ACCURACY PRODUCTS

ThermoSync® Thermowells & Temperature Probes
Direct-Mount® Systems
Square Root Error (SRE) & Gauge Line Error (GLE) Indicators

ZEUS® POWER SYSTEMS

TEC™ ThermoElectric Battery Chargers
DB1™ Differential Pressure Battery Chargers

ADDITIONAL PGI DIVISION PRODUCTS & SERVICES

Valve Fittings & Wellhead Components
Propane and Anhydrous Ammonia Valves
Contract Machining



16101 Vallen Drive • Houston, TX 77041 USA
713-466-0056 • 1-800-231-0233 • Fax: 1-800-568-9228

Pricing & Quotes: pgi_quotes@parker.com

Technical Support: pgi_technical@parker.com

Customer Service: pgi_sales@parker.com

www.pgint.com
www.parker.com